

03QX 三爪前置式动力卡盘

3-JAW FRONT-MOUNTED POWER CHUCK

- 内置气缸。
 - 高夹紧力，即使6bar事夹紧力也很大。
 - 安装快速简便。
 - 很容易与手动卡盘互
 - 操作简单。
 - 只能在主轴不旋转时，进行夹紧和松开操作。
- Internal air cylinder.
 - High clamping force, even 6bar, clamping force still strong.
 - Quick and easy installation.
 - Easy to interchange with hand chuck.
 - Easy operation.
 - Only when the spindle stop rotating, then can proceed clamp and loosen operation.



尺寸图 Dimensions

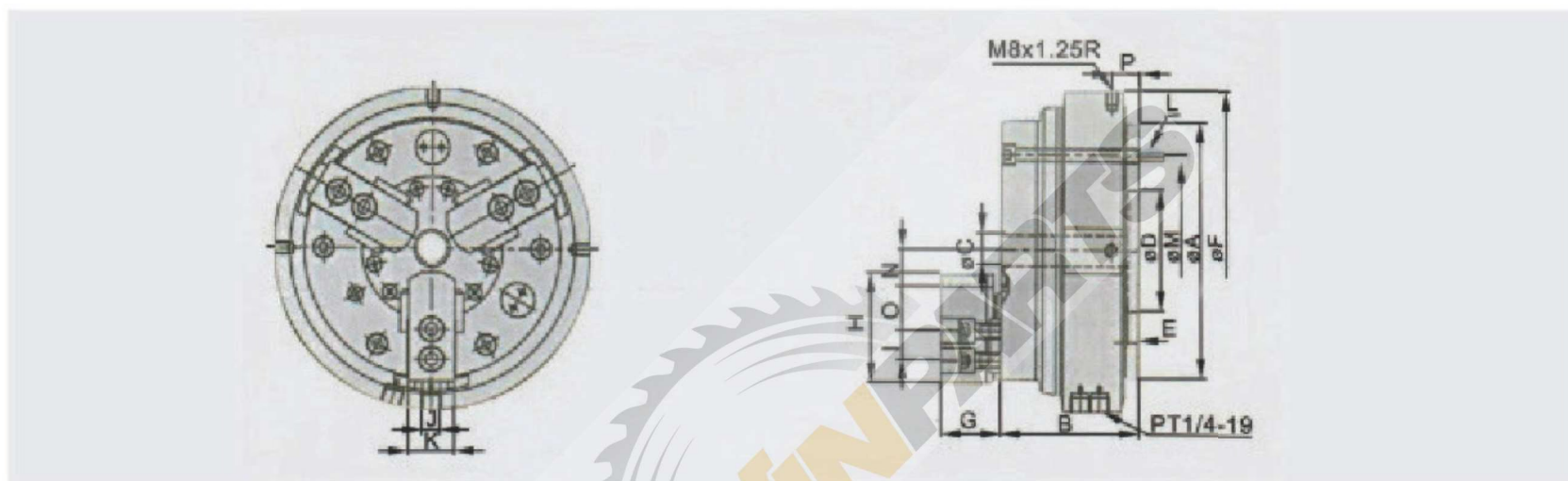

规格表 Specification

单位/UNT:mm

型号 Model	A	B	C	D	E	F	G	H	I	J	K	L
QX-05	140	85	16	60	6	182	33.6	62	14	10	25	6-M8×1.25P
QX-06	170	95	21	80	7	215	40.4	73	20	12	31	6-M8×1.25P
QX-08	215	112	30	110	8	255	42.4	95	25	14	35	6-M8×1.25P
QX-10	255	120	43	140	8	300	46.4	110	30	16	40	6-M8×1.25P

型号 Model	M	P	N (max)	N (min)	O (max)	O (min)	通孔直径 Thru-Hole Diameter (mm)	活塞面积 Piston Area (cm ²)	柱塞行程 Plunger Stroke (mm)	爪行程 Jaw stroke (mm)
QX-05	PCD ϕ 118	18.5	26.93	24.62	20.05	6.55	16	74	10	4.6
QX-06	PCD ϕ 147	18.5	36.46	33.69	21.55	15.55	21	120	13	5.5
QX-08	PCD ϕ 185	19.5	44.92	41.52	29.55	17.55	30	190	16	6.8
QX-10	PCD ϕ 220	21.5	53.63	49.59	36.55	17.05	43	280	19	8.0

型号 Model	旋转扭矩 Torque		最高转速 Max.Speed r.p.m(min ⁻¹)	最大设定压力 Max.pressure		气压夹持力 Gripping Force At Air Pressure 7kgf/cm ² (0.7mpa)		夹持范围 Gripping Range	净重 Weight (kg)
	m	(K.m)		kg/cm ²	(Mpa)	kgf	(KN)		
QX-05	1	(9.8)	180	7	(0.7)	1340	(13.1)	ϕ 4- ϕ 136	10
QX-06	1	(9.8)	150	7	(0.7)	2330	(22.8)	ϕ 25- ϕ 166	16.8
QX-08	1	(9.8)	120	7	(0.7)	3730	(36.5)	ϕ 33- ϕ 215	30.6
QX-10	1	(9.8)	100	7	(0.7)	5480	(53.7)	ϕ 43- ϕ 255	45.1