

# 5069# SD3-60/80 鑽孔主軸頭 Drilling Head Units

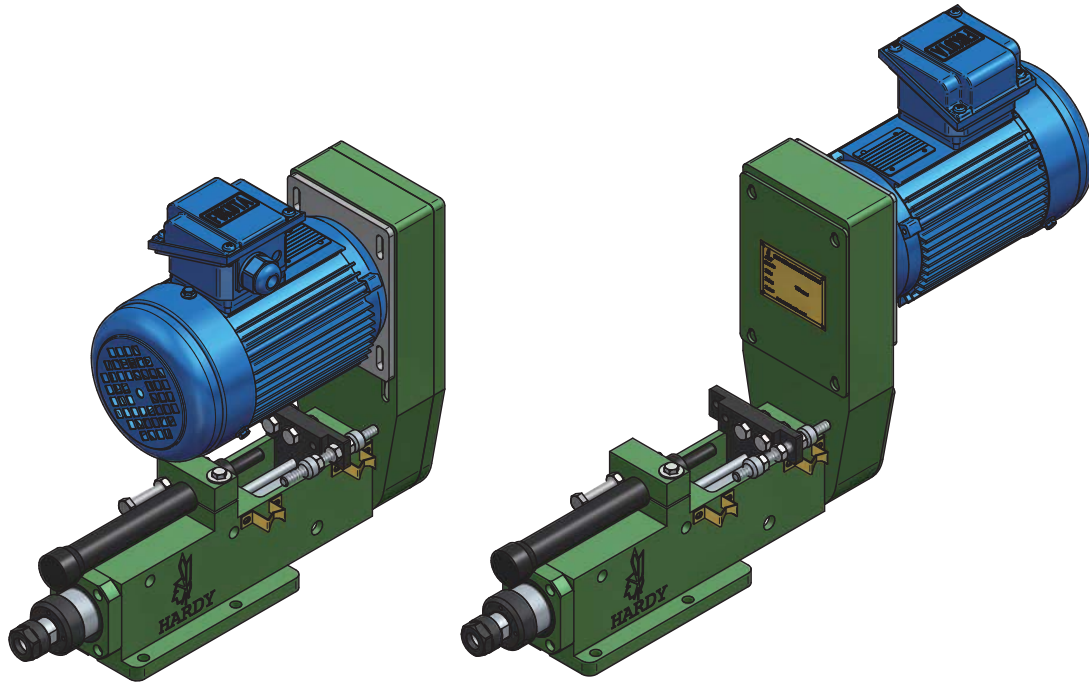

穩速器可選配美製 - 白馬牌

規格	Model	SD3-60	SD3-80	SD3A-55	SD3A-75
鑽孔能力	Drilling Capacity (S45C)	φ 6 mm			
最大行程	Max. Stroke	60mm	80mm	55mm	75mm
最高轉速	Max. RPM	10000 RPM			
推進壓力	Propel Pressure	油壓 (H) 10~15 kg/cm <sup>2</sup>		空壓 (A) 4~8 kg/cm <sup>2</sup>	
油缸面積	Cylinder Diameter	前進 (F) 12.6 cm <sup>2</sup> 後退 (B) 7.1 cm <sup>2</sup>			
馬力	Horsepower, 3 Phase	1/2 HP, 220V/380V, 三相			
傳動皮帶	Transmission Belt	5J - 200			
主軸軸承	Spindle Bearing	6002ZZx4			
皮帶輪軸承	Pulley Bearing	6002ZZx3			
前蓋油封	Front Cover Seal	TC40-50-8x1		TC40-50-8x1	
活塞O型環	Piston O-ring	AP-326x2, AG-45x2, AG-40x2		UH40x2, AG-45x2, AG-40x1	
前蓋O型環	Front Cover O-ring	TC30-40-7x1			
後蓋油封	Back Cover Seal	AG-45x2, UH30x1		AG-45x1, AG-30x2	
後蓋O型環	Back Cover O-ring	AG-45x1, AG-30x2			

Roundness: ≤0.003mm



# 5069# SD3-60 鑽孔主軸頭 Drilling Head Units

SD3-60-ER16-FL(左向) / FR(右向)  
SD3-60-JT1-FL(左向) / FR(右向)  
SD3-60-JT2-FL(左向) / FR(右向)  
SD3-60-KH14E-FL(左向) / FR(右向)

重量	Weight	21 kg
----	--------	-------

穩速器可選配  
美製白馬牌

JT1      JT2

KH14E

ER16

SD3-60-ER16-BL(左向) / BR(右向)  
SD3-60-JT1-BL(左向) / BR(右向)  
SD3-60-JT2-BL(左向) / BR(右向)  
SD3-60-KH14E-BL(左向) / BR(右向)

重量	Weight	21 kg
----	--------	-------

穩速器可選配  
美製白馬牌

JT1      JT2

KH14E

ER16



# 5069# SD3-80 鑽孔主軸頭 Drilling Head Units

SD3-80-ER16-FL(左向) / FR(右向)  
SD3-80-JT1-FL(左向) / FR(右向)  
SD3-80-JT2-FL(左向) / FR(右向)

重量	Weight	21 kg
----	--------	-------

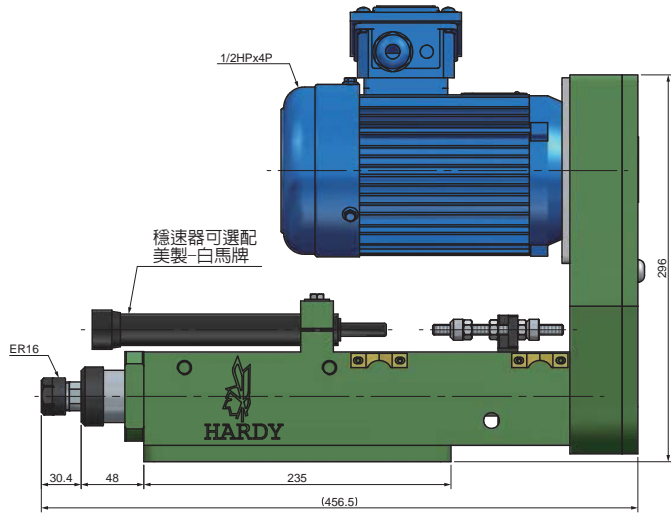
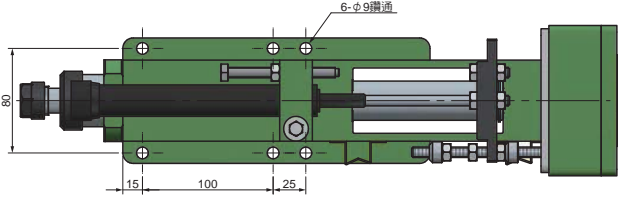
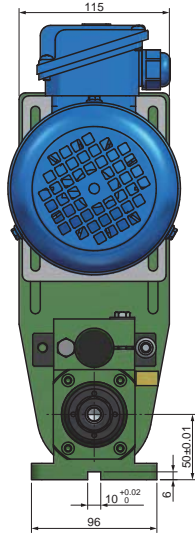
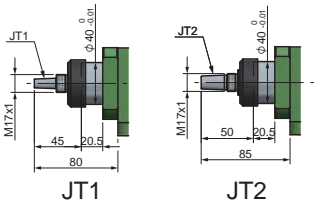
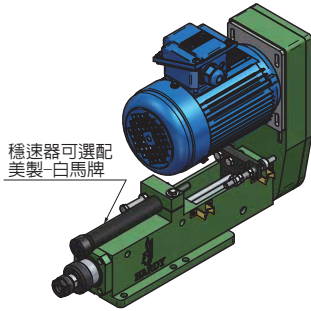

SD3-80-ER16-BL(左向) / BR(右向)  
SD3-80-JT1-BL(左向) / BR(右向)  
SD3-80-JT2-BL(左向) / BR(右向)

重量	Weight	21 kg
----	--------	-------

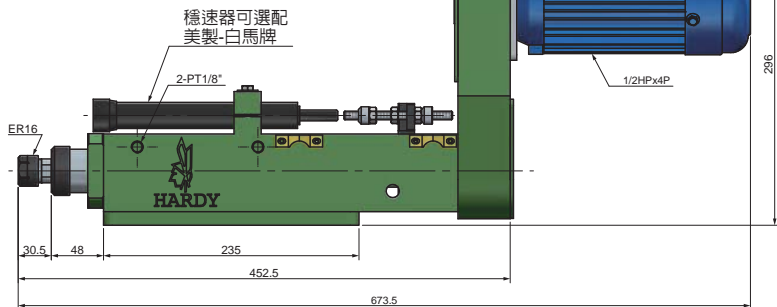
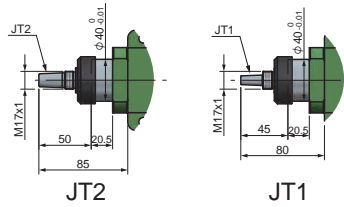
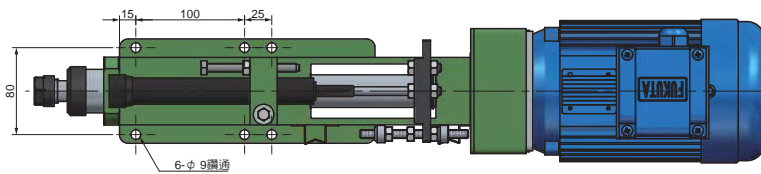
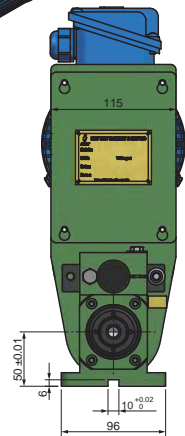
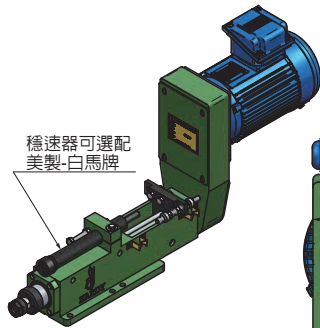





# 5069# SD3A-55 鑽孔主軸頭-空壓 Drilling Head Units-Pneumatic

空壓Pneumatic SD3A-55-ER16-FL(左向) / FR(右向)  
 空壓Pneumatic SD3A-55-JT1-FL(左向) / FR(右向)  
 空壓Pneumatic SD3A-55-JT2-FL(左向) / FR(右向)  
 空壓Pneumatic SD3A-55-KH14E-FL(左向) / FR(右向)

重量	Weight	21 kg
----	--------	-------

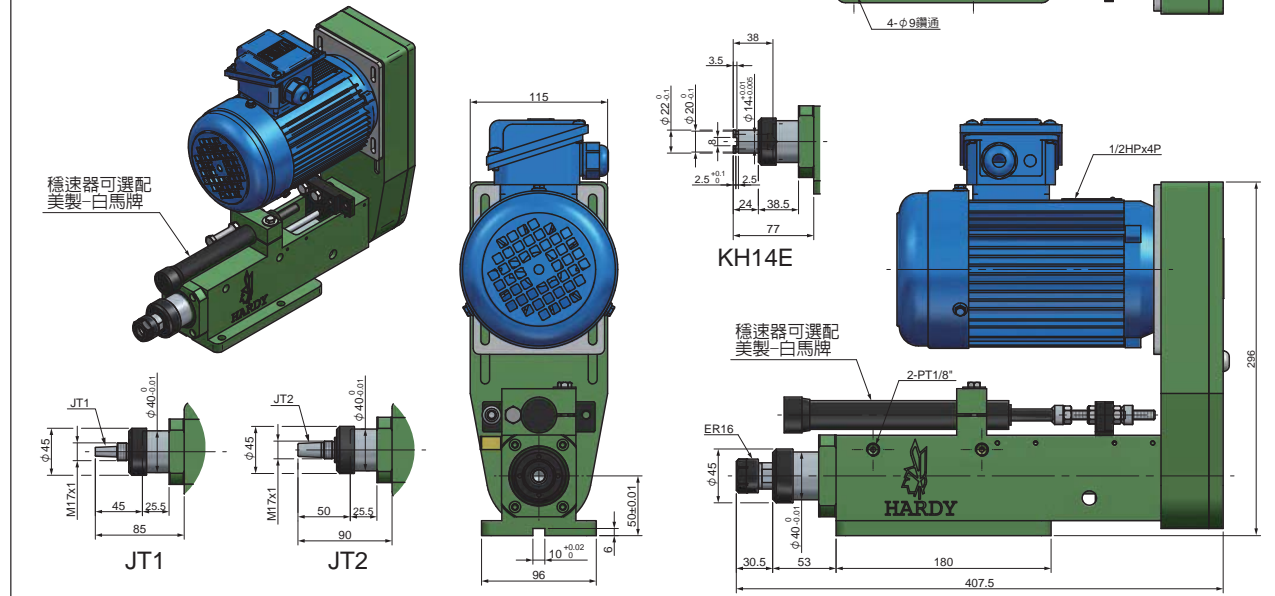

空壓Pneumatic SD3A-55-ER16-BL(左向) / BR(右向)  
 空壓Pneumatic SD3A-55-JT1-BL(左向) / BR(右向)  
 空壓Pneumatic SD3A-55-JT2-BL(左向) / BR(右向)  
 空壓Pneumatic SD3A-55-KH14E-BL(左向) / BR(右向)

重量	Weight	21 kg
----	--------	-------

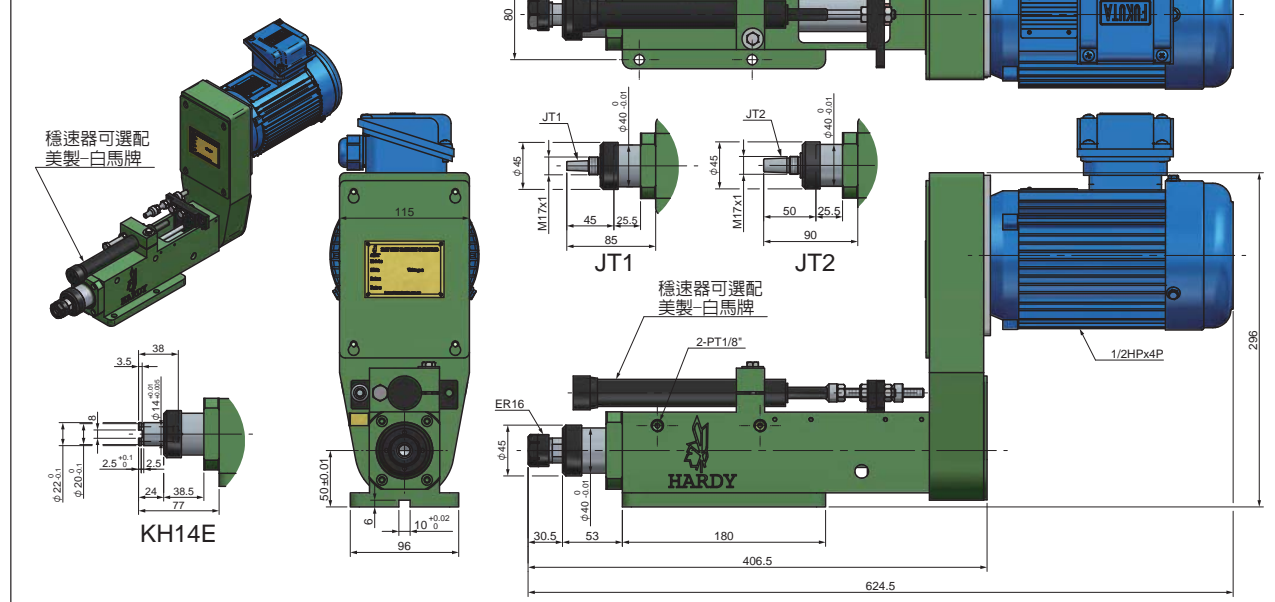



# 5069# SD3A-75 鑽孔主軸頭-空壓 Drilling Head Units-Pneumatic

空壓Pneumatic SD3A-75-ER16-FL(左向) / FR(右向)  
 空壓Pneumatic SD3A-75-JT1-FL(左向) / FR(右向)  
 空壓Pneumatic SD3A-75-JT2-FL(左向) / FR(右向)

重量	Weight	21 kg
----	--------	-------

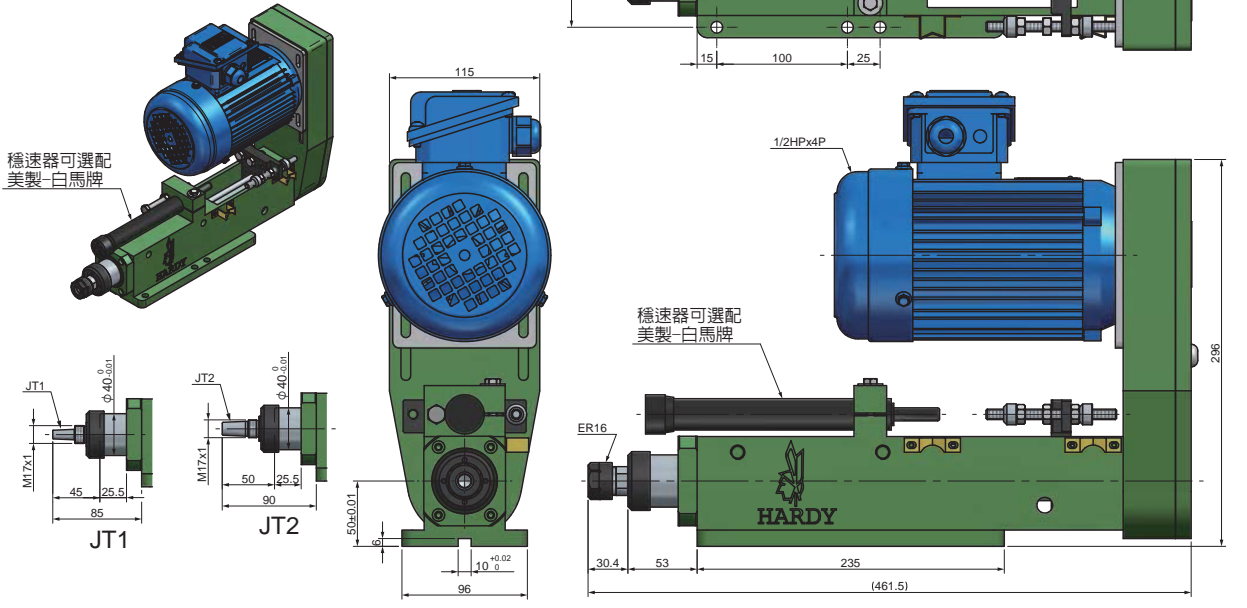

空壓Pneumatic SD3A-75-ER16-BL(左向) / BR(右向)  
 空壓Pneumatic SD3A-75-JT1-BL(左向) / BR(右向)  
 空壓Pneumatic SD3A-75-JT2-BL(左向) / BR(右向)

重量	Weight	21 kg
----	--------	-------

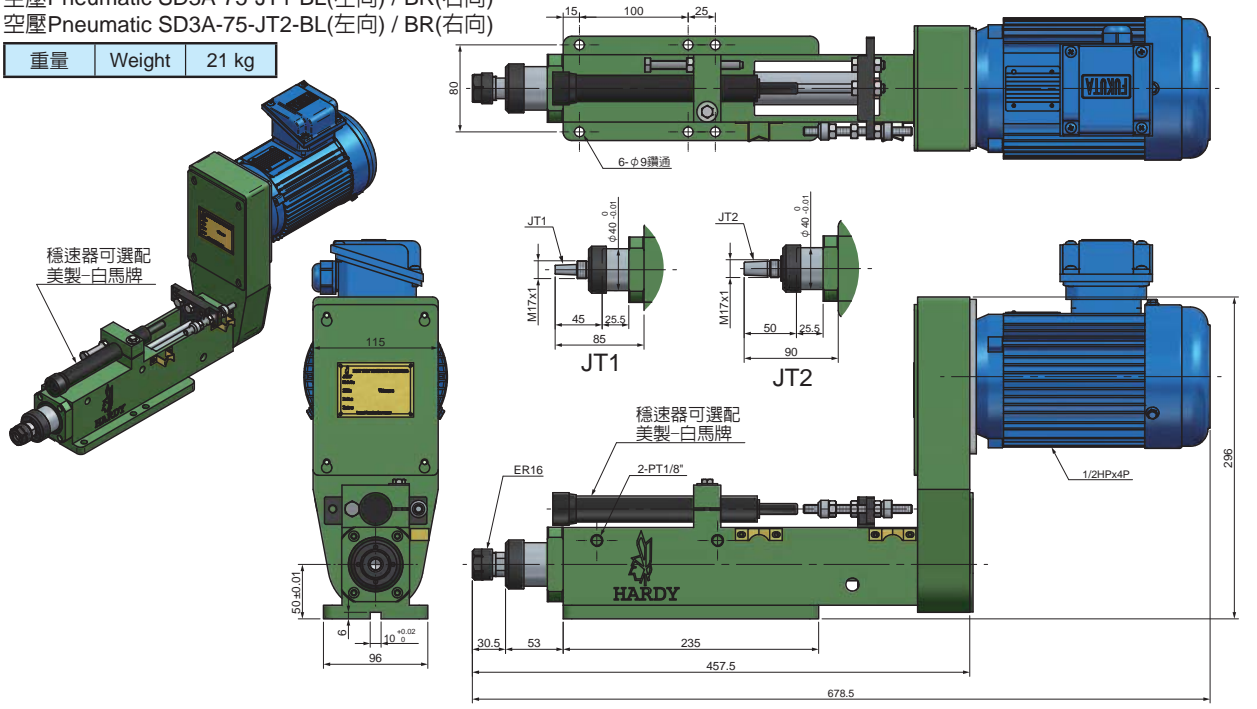

## 5070# SD5-85 鑽孔主軸頭 Drilling Head Units



穩速器可選配美製 - 白馬牌

規 格	Model	SD5-85	SD5A-80
鑽孔能力	Drilling Capacity (S45C)	φ 13mm	
最大行程	Max. Stroke	85mm	80mm
最高轉速	Max. RPM	5000 RPM	
推進壓力	Propel Pressure	油壓 (H) 20~25 kg/cm <sup>2</sup>	空壓 (A) 4~8 kg/cm <sup>2</sup>
油缸面積	Cylinder Diameter	前進 (F) 21.5 cm <sup>2</sup> 後退 (B) 11.5 cm <sup>2</sup>	
馬 力	Horsepower, 3 Phase	1HP, 220V/380V	
傳動皮帶	Transmission Belt	5M - 615	
主軸軸承	Spindle Bearing	6004ZZx4	
皮帶輪軸承	Pulley Bearing	6203ZZx3	
前蓋油封	Front Cover Seal	DKB 50-62-10x1	
活塞O型環	Piston O-ring	AP-53x3	UHA-53x2
前蓋O型環	Front Cover O-ring	AG-58x2, AP-50x2 AG-68x1	AG-58x2, AP-50x1 AG-50x1, AG-68x1
後蓋油封	Back Cover Seal	TC35-45-8x1	
後蓋O型環	Back Cover O-ring	AG-58x2 UH-35-45-6x1	AG-58x2 UHA-35-45-6x1

Roundness: ≤0.003mm





**HARDY**

## 5070# SD5-85 鑽孔主軸頭 Drilling Head Units

油壓Hydraulic SD5-85-ER20-FL(左向) / FR(右向)  
油壓Hydraulic SD5-85-JT6-FL(左向) / FR(右向)

重量	Weight	39 kg
----	--------	-------

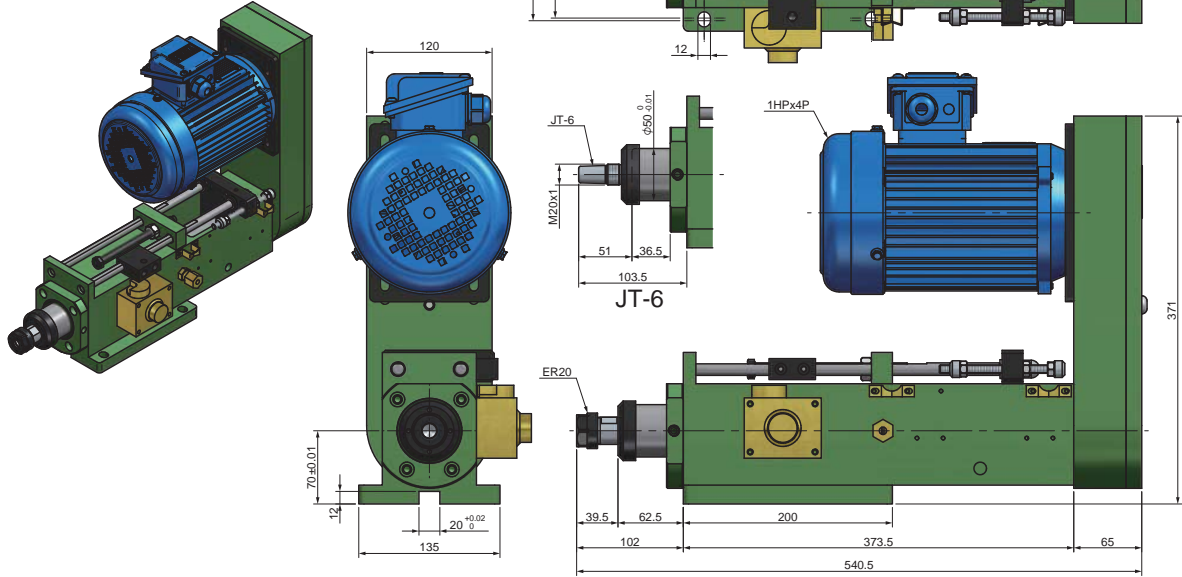

油壓Hydraulic SD5-85-ER20-BL(左向) / BR(右向)  
油壓Hydraulic SD5-85-JT6-BL(左向) / BR(右向)

重量	Weight	39 kg
----	--------	-------

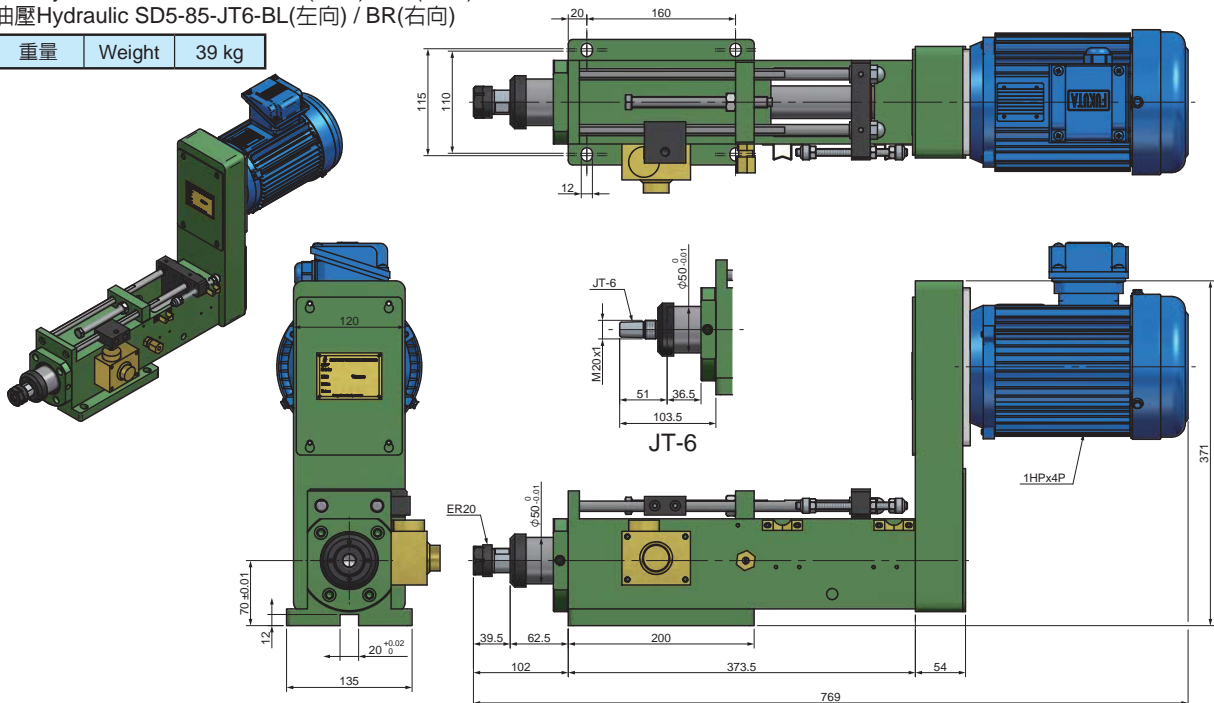



# 5070# SD5A-80 鑽孔主軸頭-空壓 Drilling Head Units-Pneumatic

空壓Pneumatic SD5A-80-ER20-FL(左向) / FR(右向)  
空壓Pneumatic SD5A-80-JT6-FL(左向) / FR(右向)

重量	Weight	39 kg
----	--------	-------

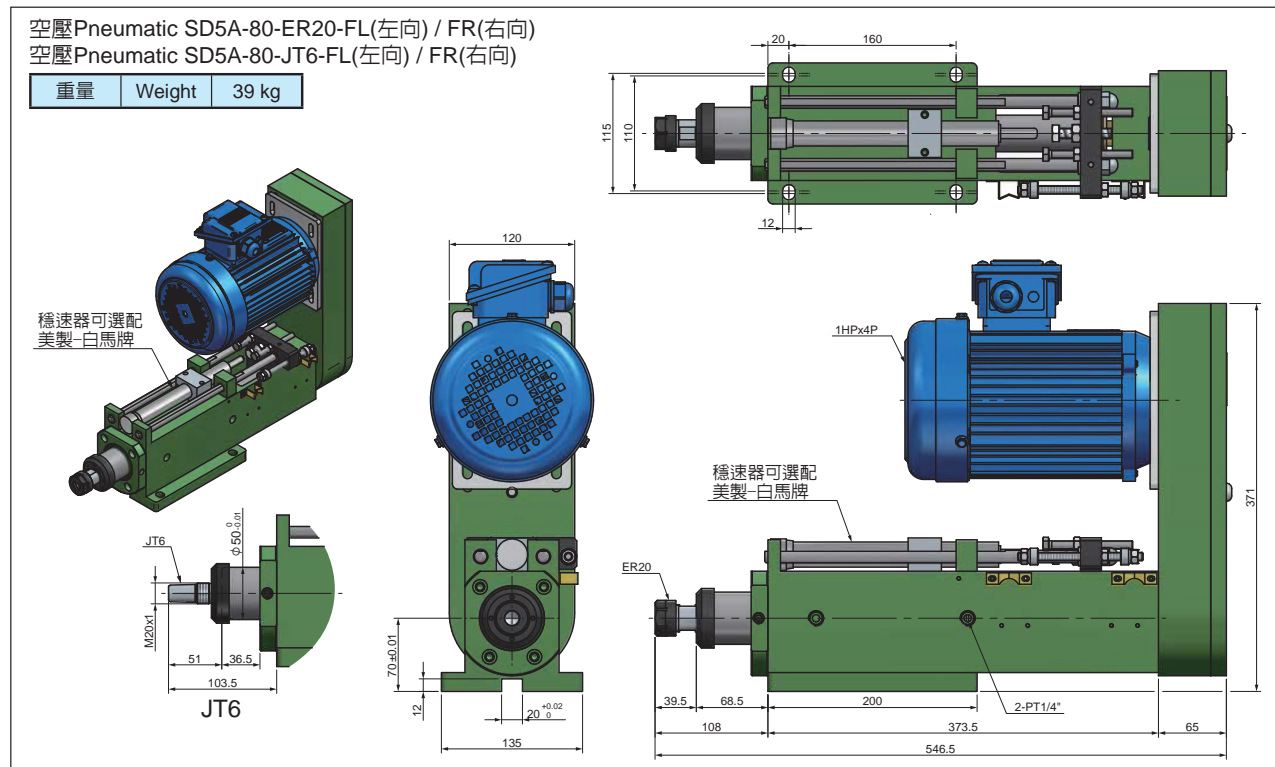

空壓Pneumatic SD5A-80-ER20-BL(左向) / BR(右向)  
空壓Pneumatic SD5A-80-JT6-BL(左向) / BR(右向)

重量	Weight	39 kg
----	--------	-------

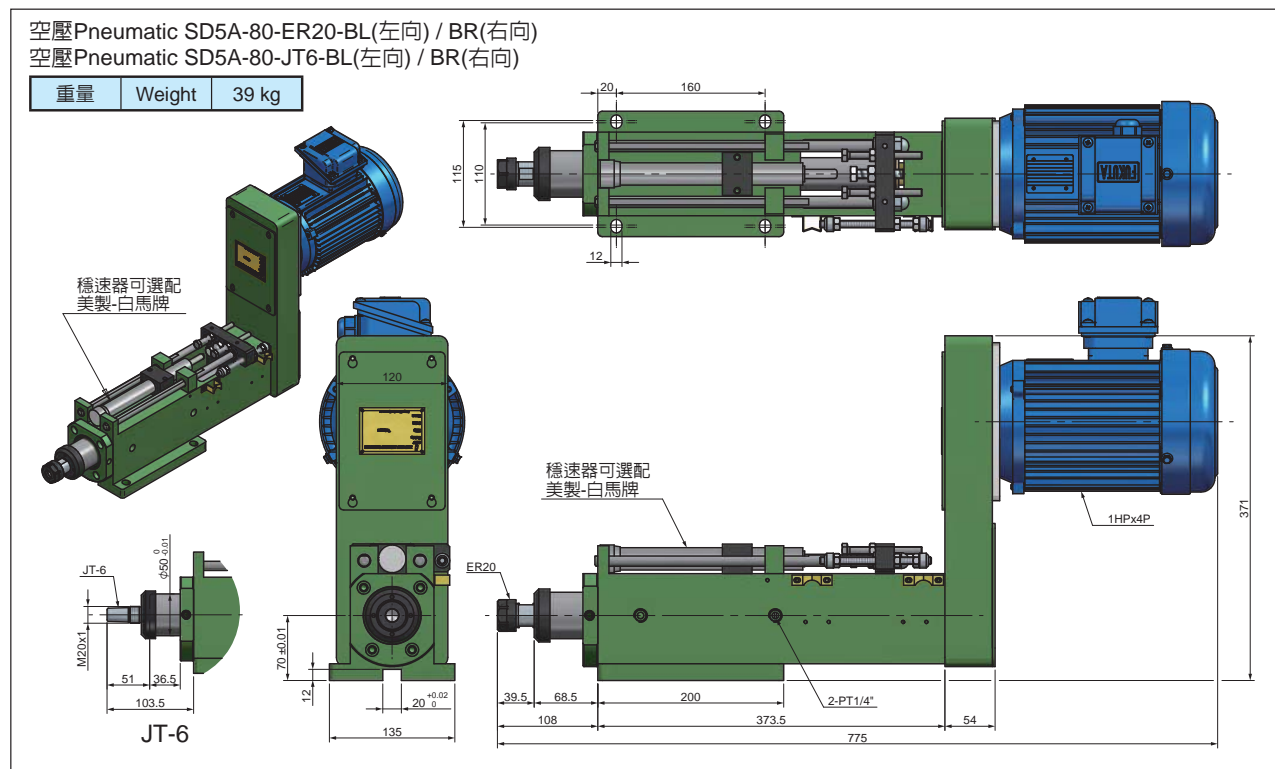



## 5071# SD7-130 鑽孔主軸頭 Drilling Head Units



馬達板型組合

規 格	Model	SD7-130
鑽孔能力	Drilling Capacity (S45C)	φ 20 mm
最大行程	Max. Stroke	130 mm
最高轉速	Max. RPM	2500 RPM
推進壓力	Propel Pressure	油壓 (H) 20~30 kg/cm <sup>2</sup>
油缸面積	Cylinder Diameter	前進 (F) 37 cm <sup>2</sup> 後退 (B) 15.9 cm <sup>2</sup>
馬 力	Horsepower, 3 Phase	1 HP, 220V / 380V
傳動皮帶	Transmission Belt	A2×φ 100, 8M×40T×50W
主軸軸承	Spindle Bearing	6004Z, 32004 6005Z, 32005
皮帶輪軸承	Pulley Bearing	6008Z, 51208
前蓋油封	Front Cover Seal	TC60-70-10×1
活塞O型環	Piston O-ring	AP-65×2, AG-35×1, TC32-52-10×1
前蓋O型環	Front Cover O-ring	AP-60×2, AG-70×1, AG-80×1
後蓋O型環	Back Cover O-ring	AP-30×2, AG-70×1, AG-80×1

Roundness: ≤0.003mm

# 5071# SD7-130 鑽孔主軸頭 Drilling Head Units

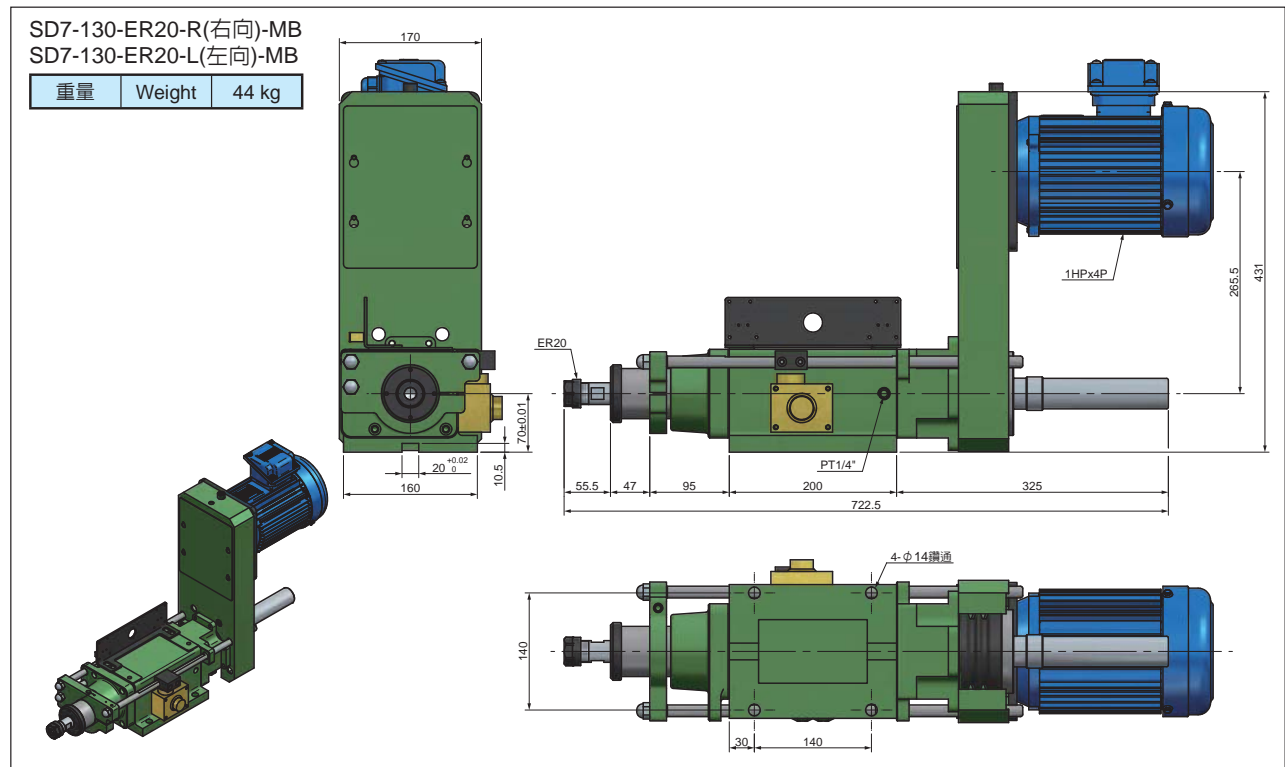
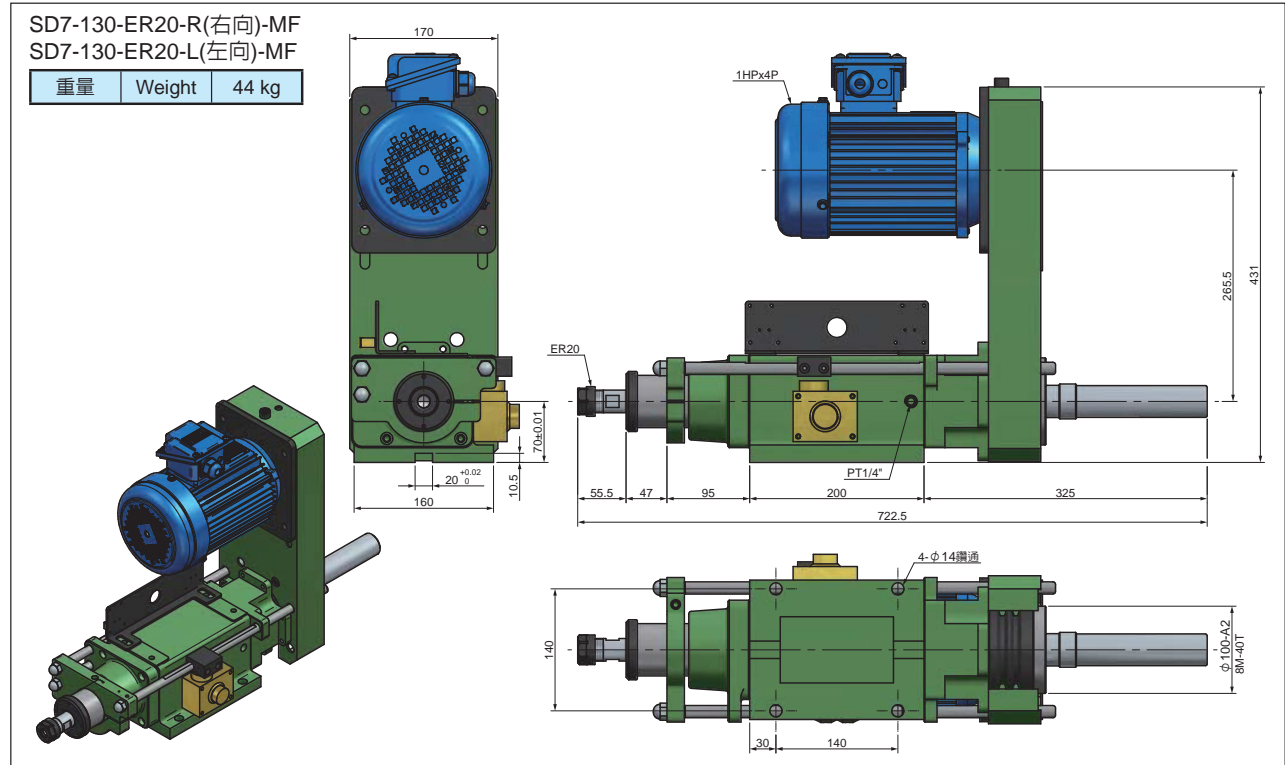



**HARDY**

## 5071# SD7-130 鑽孔主軸頭 Drilling Head Units

SD7-130-ER20-AR(右向)  
SD7-130-ER20-AL(左向)

重量	Weight	54 kg
----	--------	-------

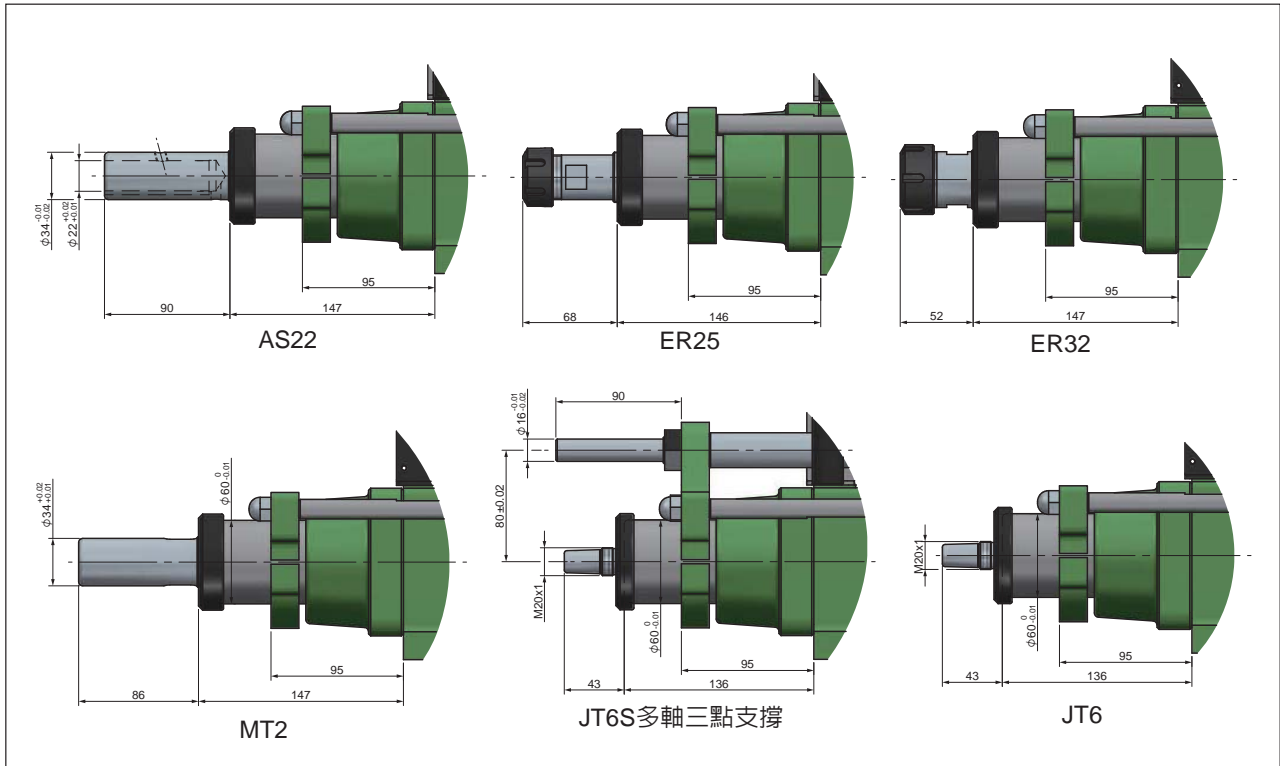
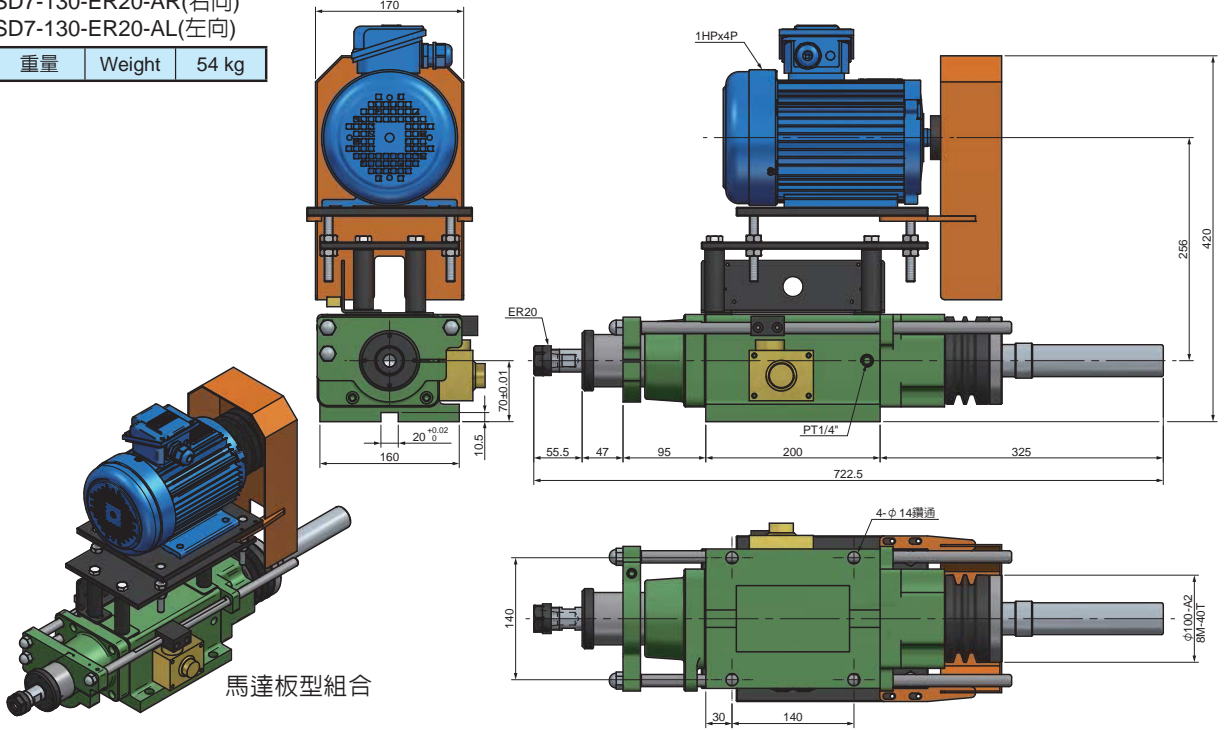



## 5072# SD8-150 鑽孔主軸頭 Drilling Head Units

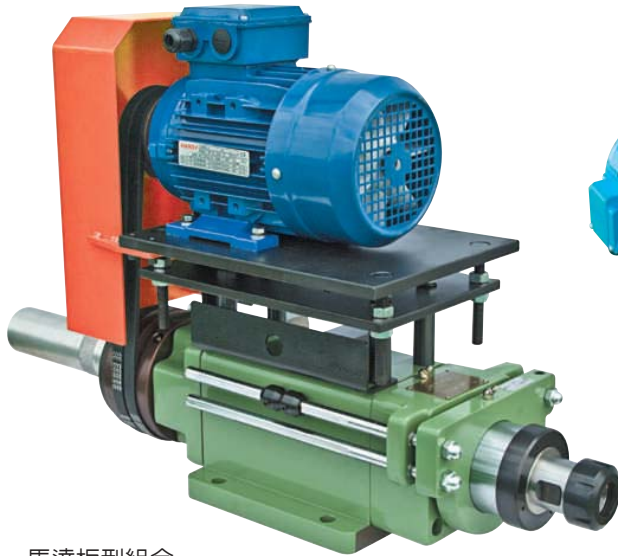

馬達板型組合

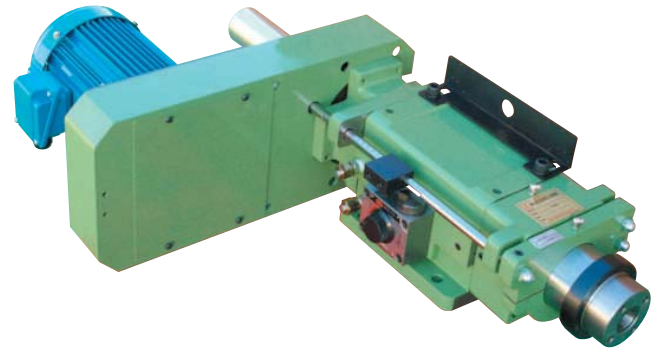

馬達盒組合

規格	Model	SD8-150
鑽孔能力	Drilling Capacity (S45C)	φ 35 mm
最大行程	Max. Stroke	150 mm
最高轉速	Max. RPM	1500 RPM
推進壓力	Propel Pressure	油壓 (H) 20~35 kg/cm <sup>2</sup>
油缸面積	Cylinder Diameter	前進 (F) 71.2 cm <sup>2</sup> 後退 (B) 31.4 cm <sup>2</sup>
馬力	Horsepower, 3 Phase	2 HP, 220V / 380V
傳動皮帶	Transmission Belt	B2×φ 150, 8M×58T×56W
主軸軸承	Spindle Bearing	6008Z, 32008 6010Z, 32010
皮帶輪軸承	Pulley Bearing	6013Z×1, 51213×1
前蓋油封	Front Cover Seal	TC90-110-12×1
活塞O型環	Piston O-ring	AP-100×3, AG-65×1, TC60-82-12×1
前蓋O型環	Front Cover O-ring	AG-100×1, AP-90×2, AG-115×1
後蓋O型環	Back Cover O-ring	AP-55×2, AG-100×1, AG-115×1

Roundness: ≤ 0.003mm



**HARDY**

## 5072# SD8-150 鑽孔主軸頭 Drilling Head Units

SD8-150-ER40-R(右向)-MF  
SD8-150-ER40-L(左向)-MF

重量	Weight	96 kg
----	--------	-------

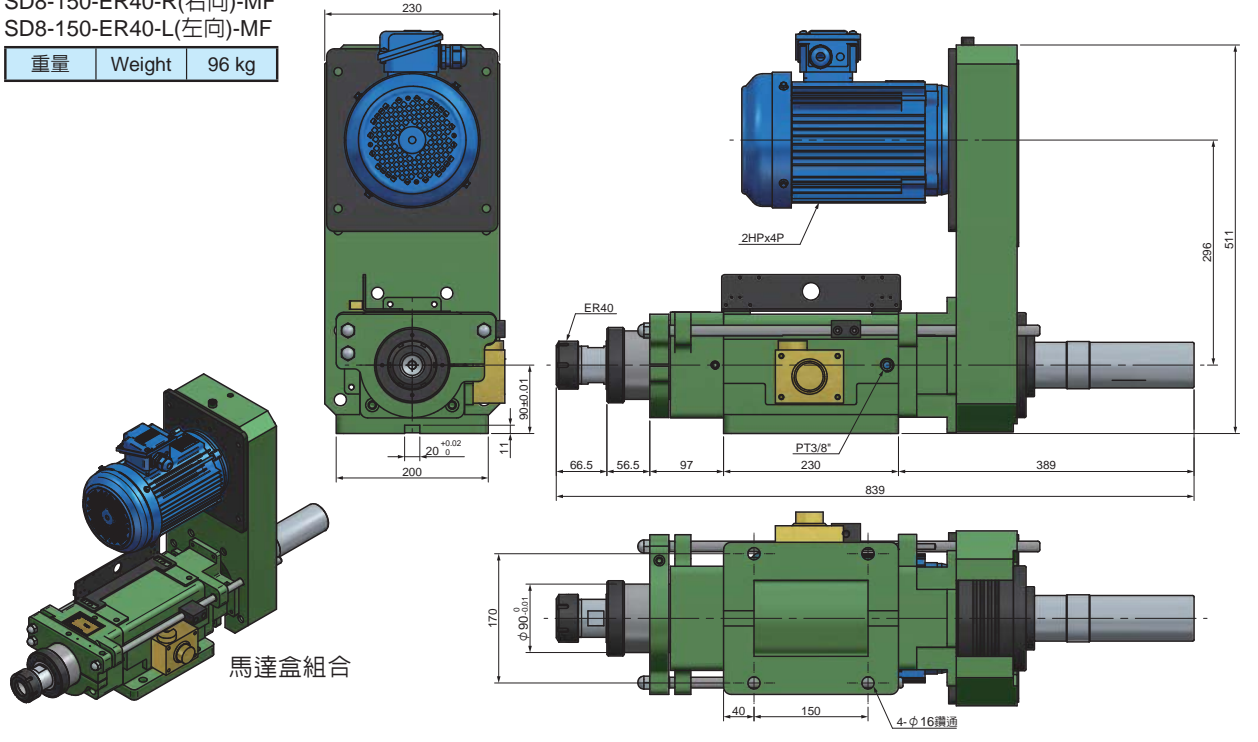

SD8-150-ER40-R(右向)-MB  
SD8-150-ER40-L(左向)-MB

重量	Weight	96 kg
----	--------	-------

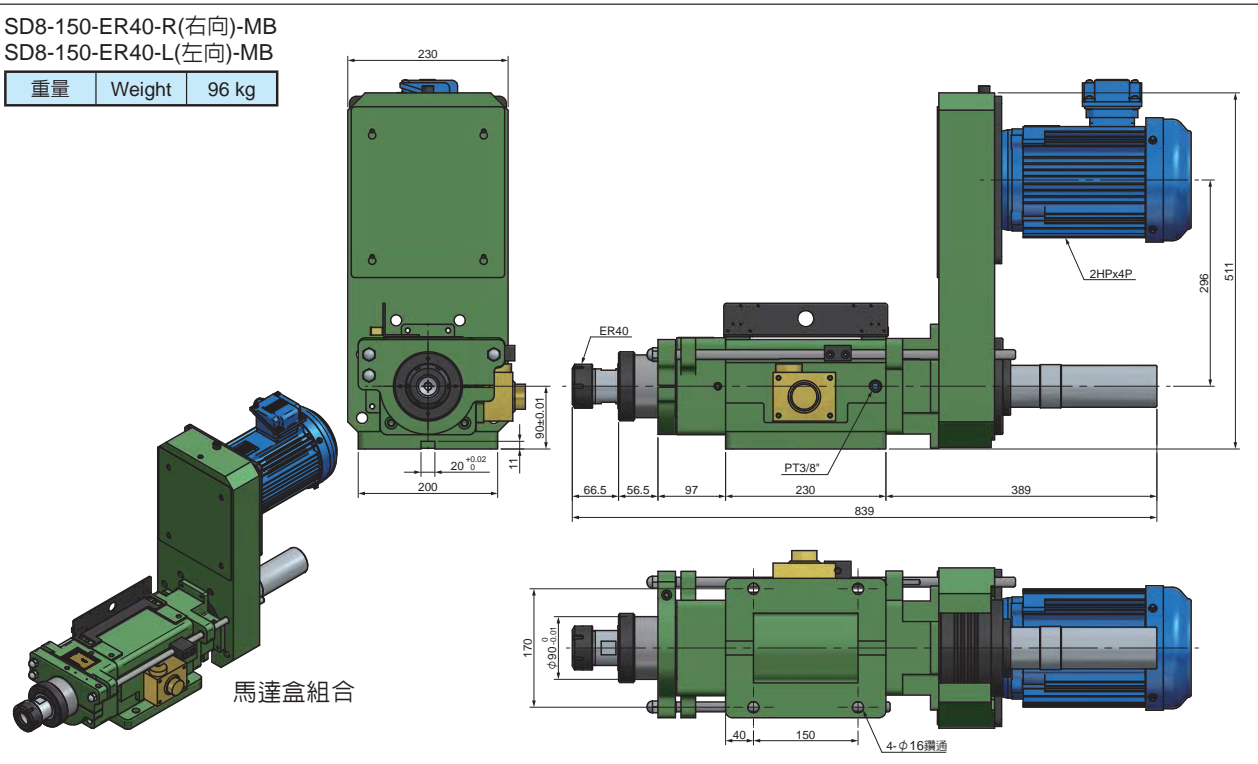



# 5072# SD8-150 鑽孔主軸頭 Drilling Head Units

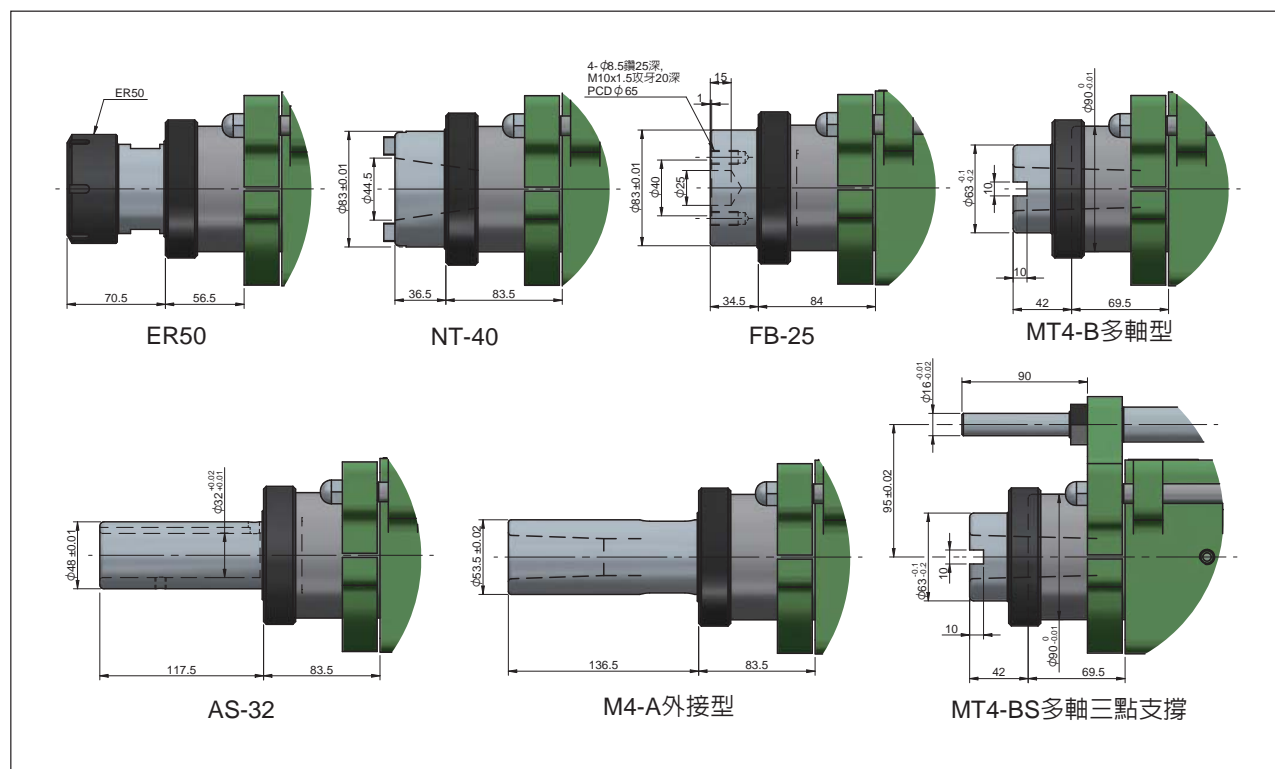
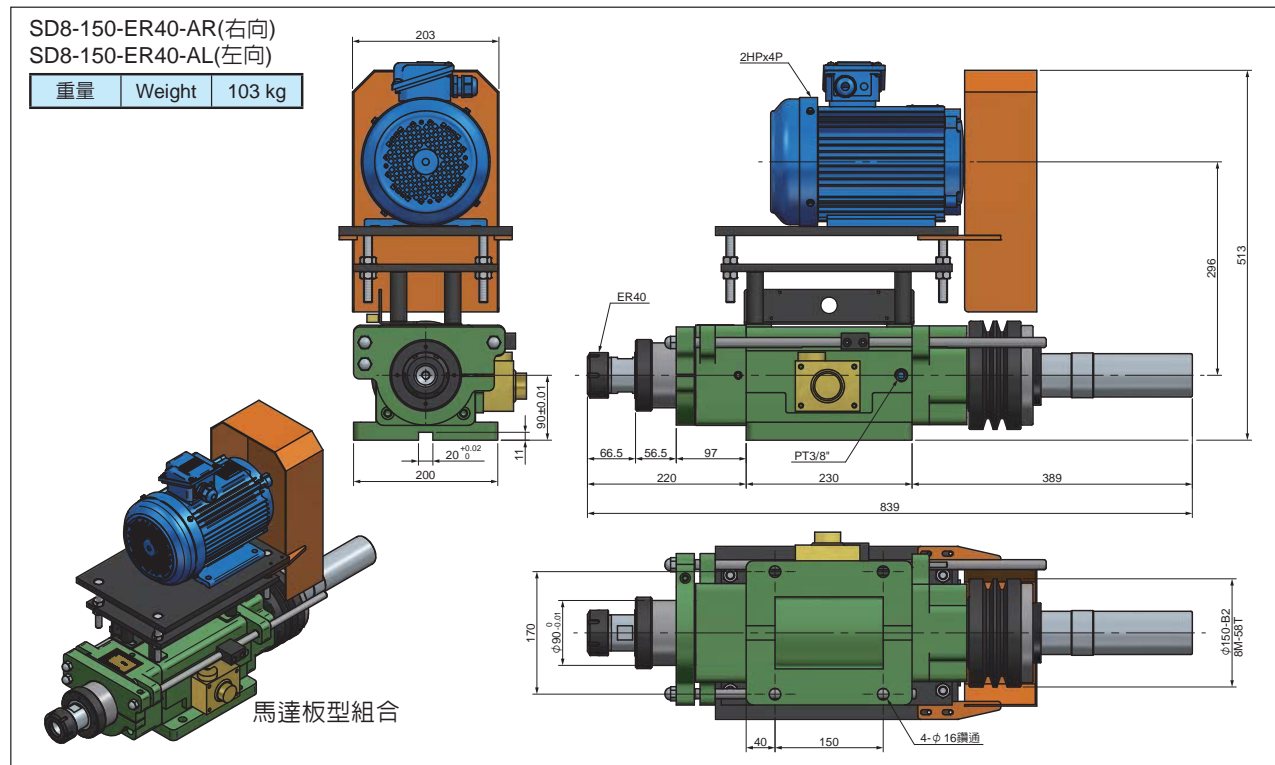





## 5073# SD09-120 油壓鑽孔/搪銑動力頭 Drilling/Milling Spindle Head-Hydraulic Type

規格	Model	SD09	SD09H
鑽孔能力	Drilling Capacity(S45C)	φ 25	
最大行程	Max. Stroke	120mm	
最高轉速	Max. RPM	3000	8000
推進壓力	Propel Pressure	油壓(H)30~40kg/cm <sup>2</sup>	
油缸面積	Cylinder Diameter	14.7cm <sup>2</sup> (缸徑φ50 : 心軸φ25)	
馬力	Horsepower	2HP×4P	
主軸皮帶輪	Spindle Pulley	5M-66T, φ 102.3×J×20	
主軸軸承	Spindle Bearing	6007Z×1 / 6006Z×1 32007×1 / 32006×1	7007×2 7006×2
皮帶輪軸承	Pulley Bearing	6010ZZ×2	
前蓋油封	Front Cover Seal	TC90-110-12×1	
主軸油封	Spindle Seal	TC50-65-8×1	

Roundness: ≤0.003mm

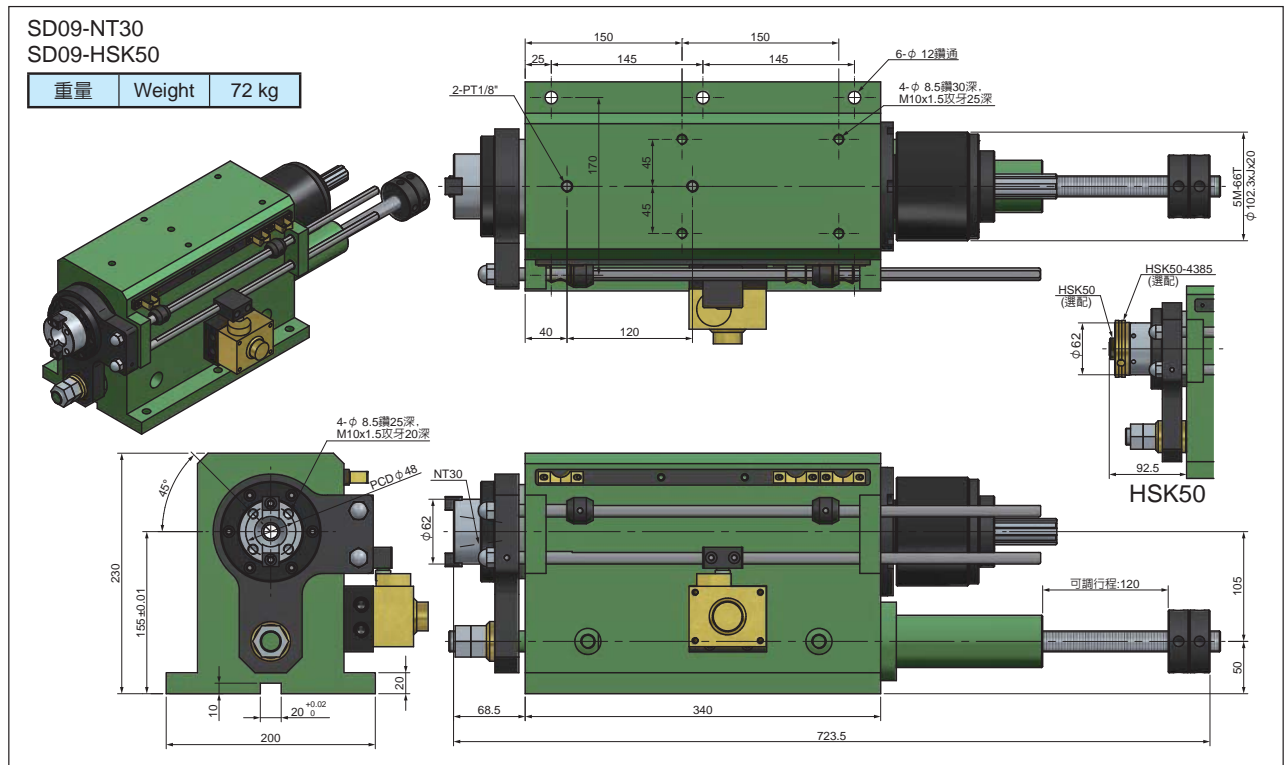

# 5073# SD09-120 油壓鑽孔/搪銑動力頭 Drilling/Milling Spindle Head-Hydraulic Type

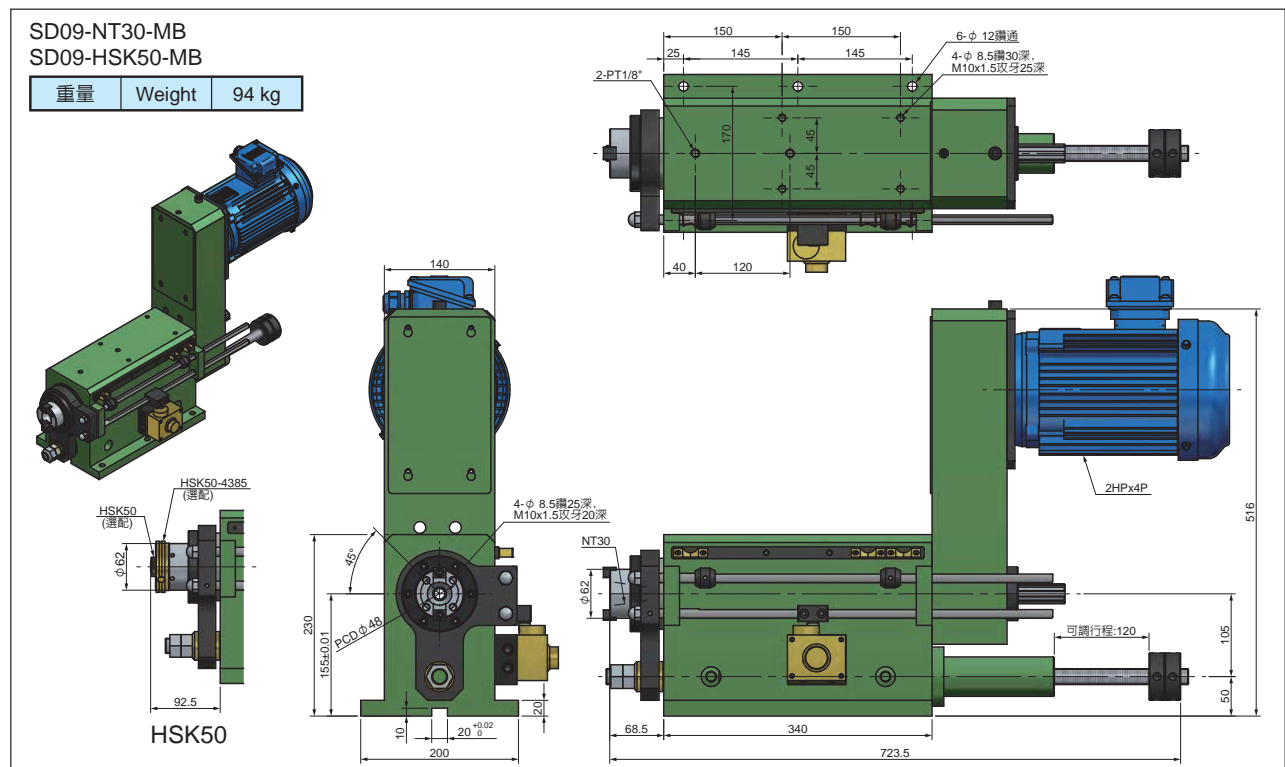
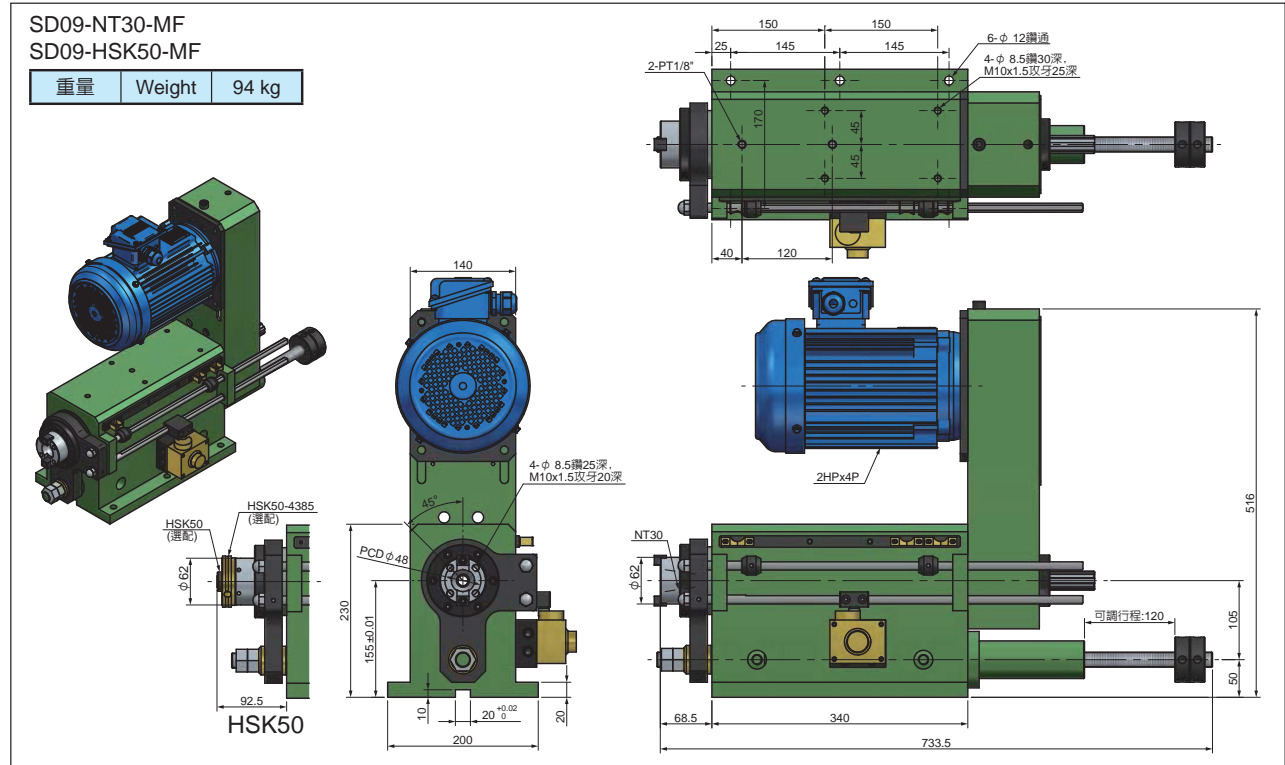



## 5074# SD12-150 油壓鑽孔/搪銑動力頭 Drilling/Milling Spindle Head-Hydraulic Type

規格	Model	SD12	SD12H
鑽孔能力	Drilling Capacity(S45C)	φ 35	
最大行程	Max. Stroke	150mm	
最高轉速	Max. RPM	2000	6000
推進壓力	Propel Pressure	油壓(H)30~40kg/cm <sup>2</sup>	
油缸面積	Cylinder Diameter	21.2cm <sup>2</sup> (缸徑φ60 : 心軸φ30)	
馬力	Horsepower	3HP×4P	
主軸皮帶輪	Spindle Pulley	8M-54T, φ 133.6xJx25	
主軸軸承	Spindle Bearing	6011Zx1 / 6009Zx1 32011x1 / 32009x1	7011x2 7009x2
皮帶輪軸承	Pulley Bearing	6211ZZx2	
前蓋油封	Front Cover Seal	TC120-145-12x1	
主軸油封	Spindle Seal	TC75-90-12x1	

Roundness: ≤0.003mm

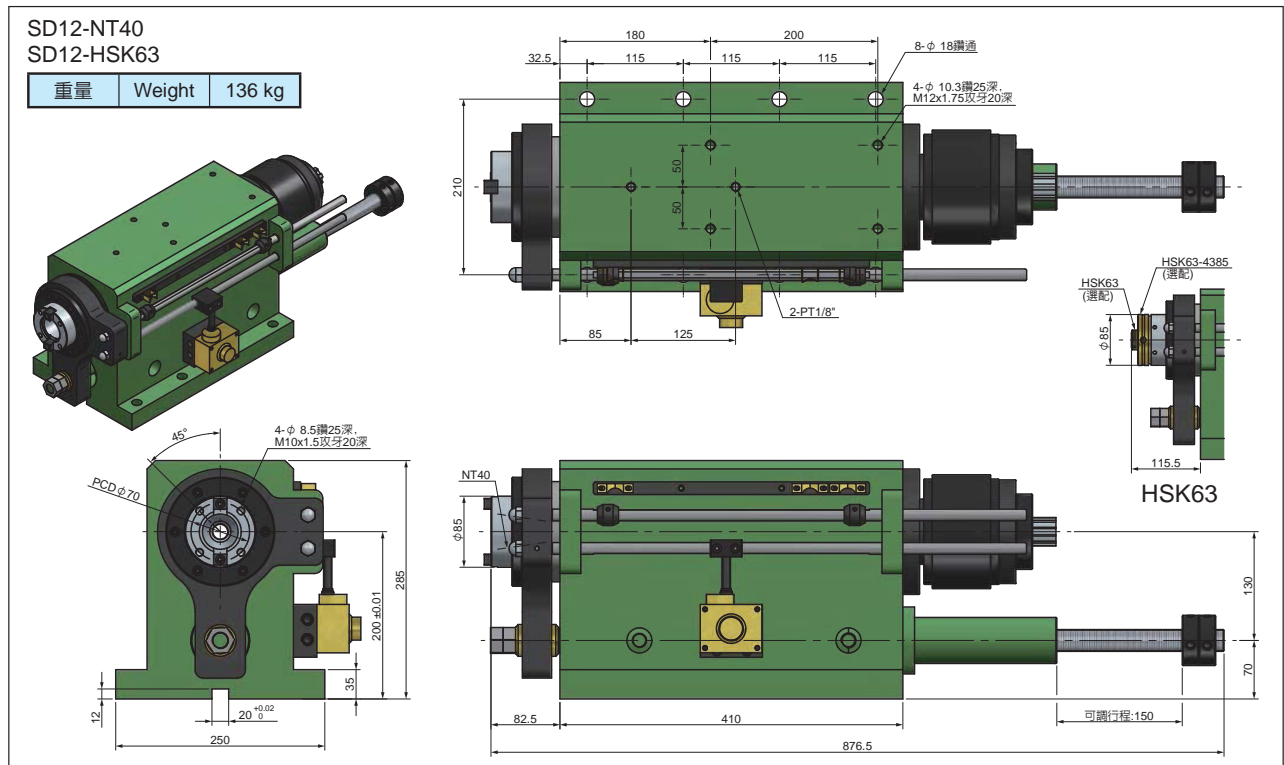





# 5074# SD12-150 油壓鑽孔/搪銑動力頭 Drilling/Milling Spindle Head-Hydraulic Type

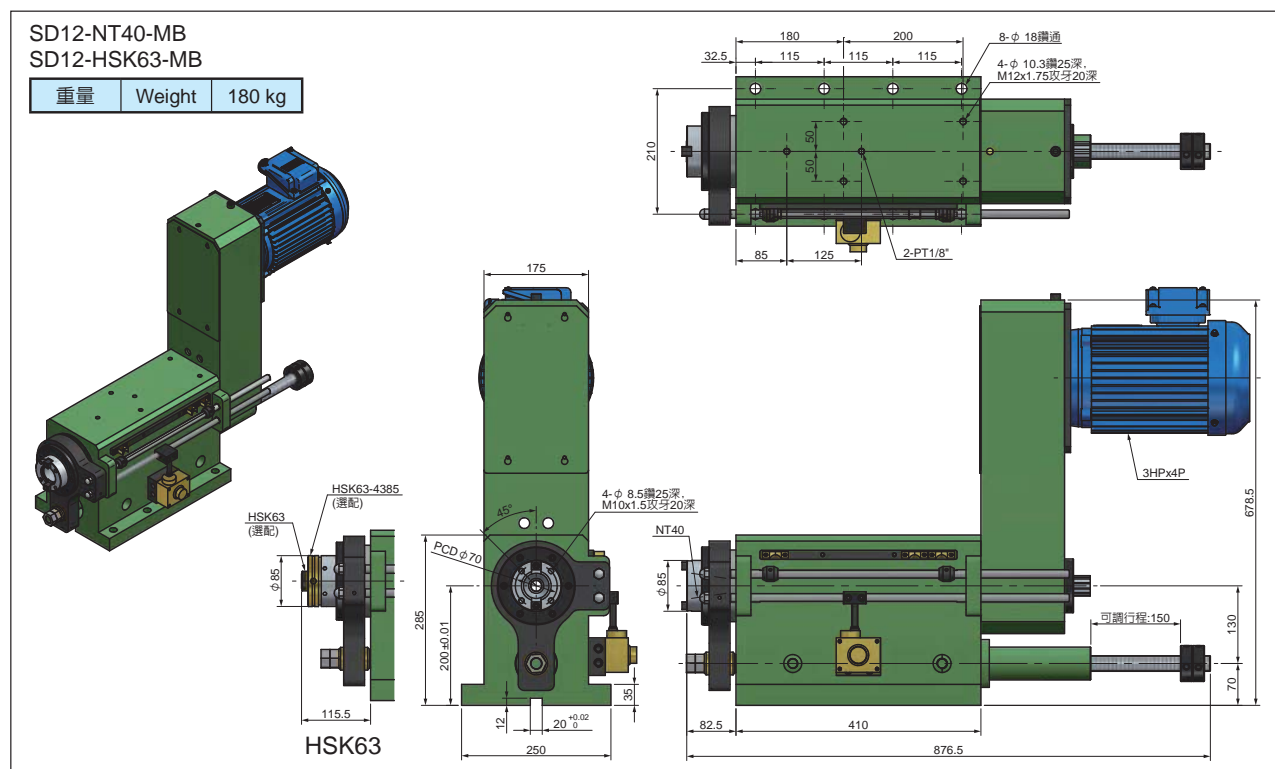
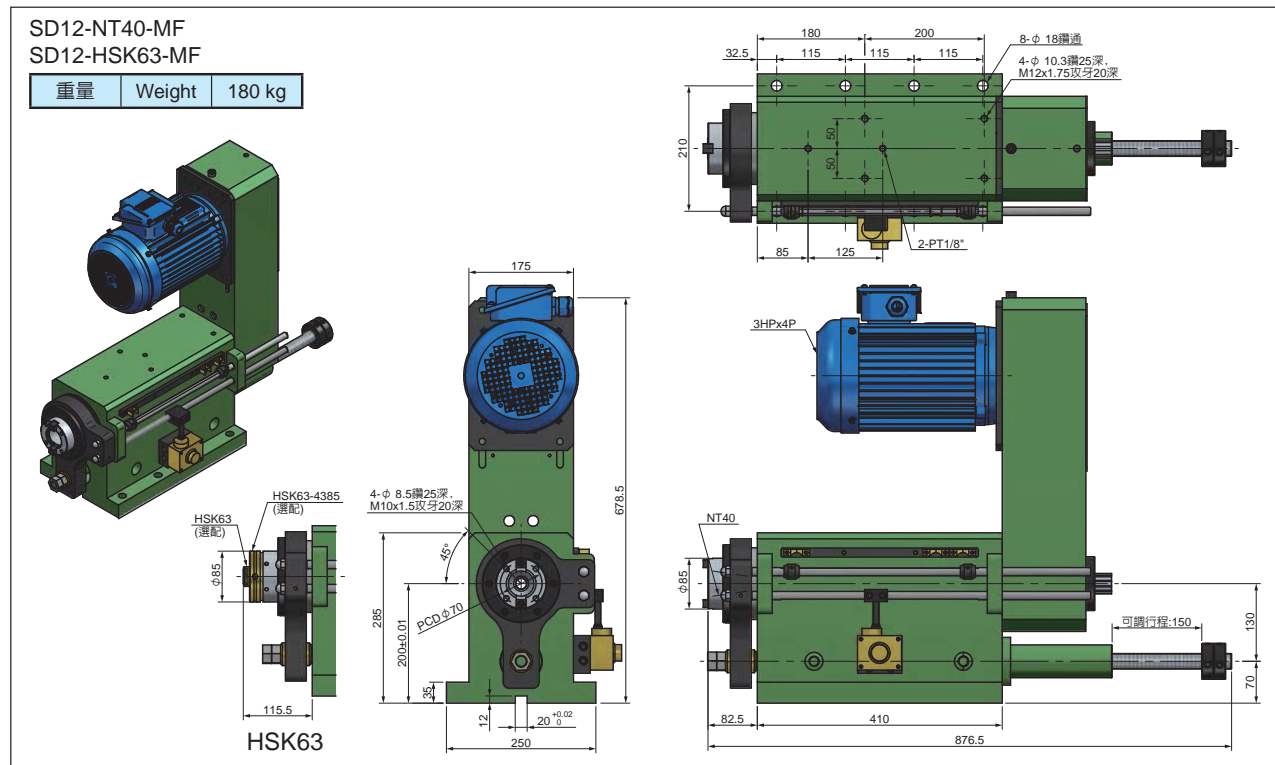



# 5075# SD15-150 油壓鑽孔/搪銑動力頭 Drilling/Milling Spindle Head-Hydraulic Type

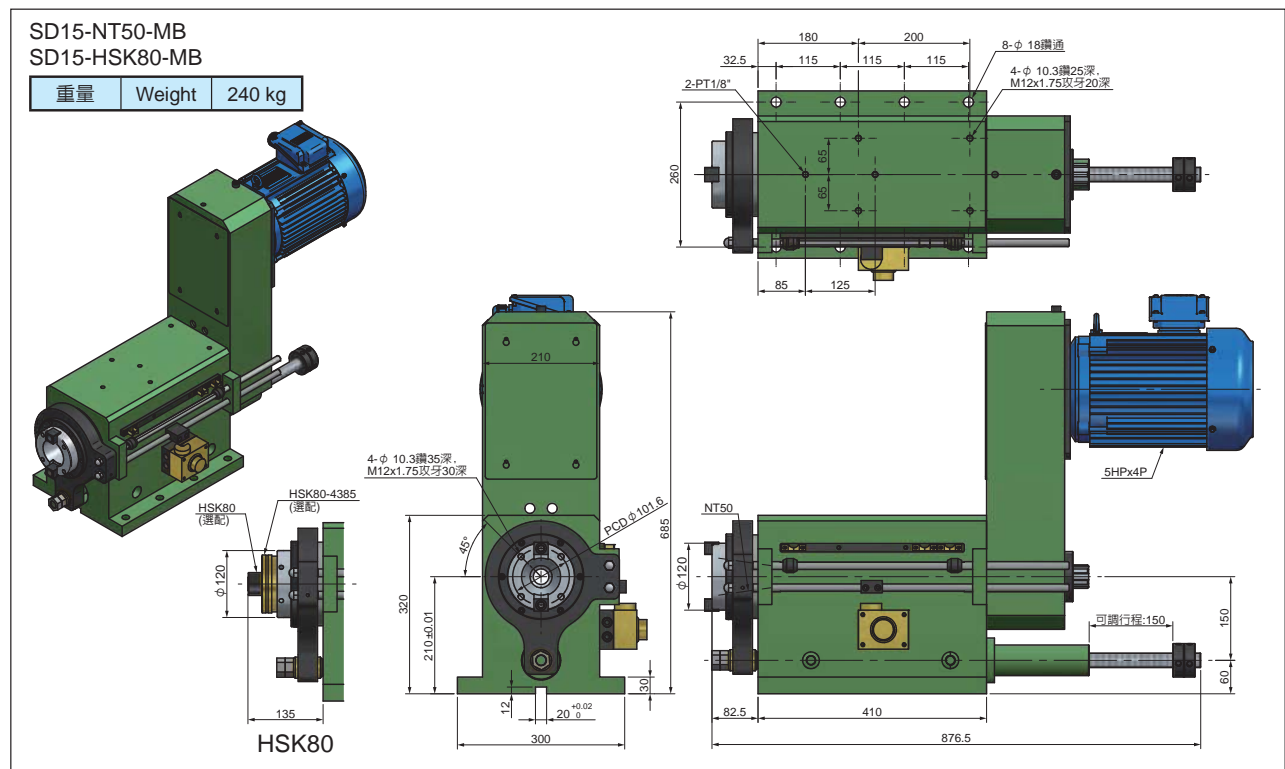
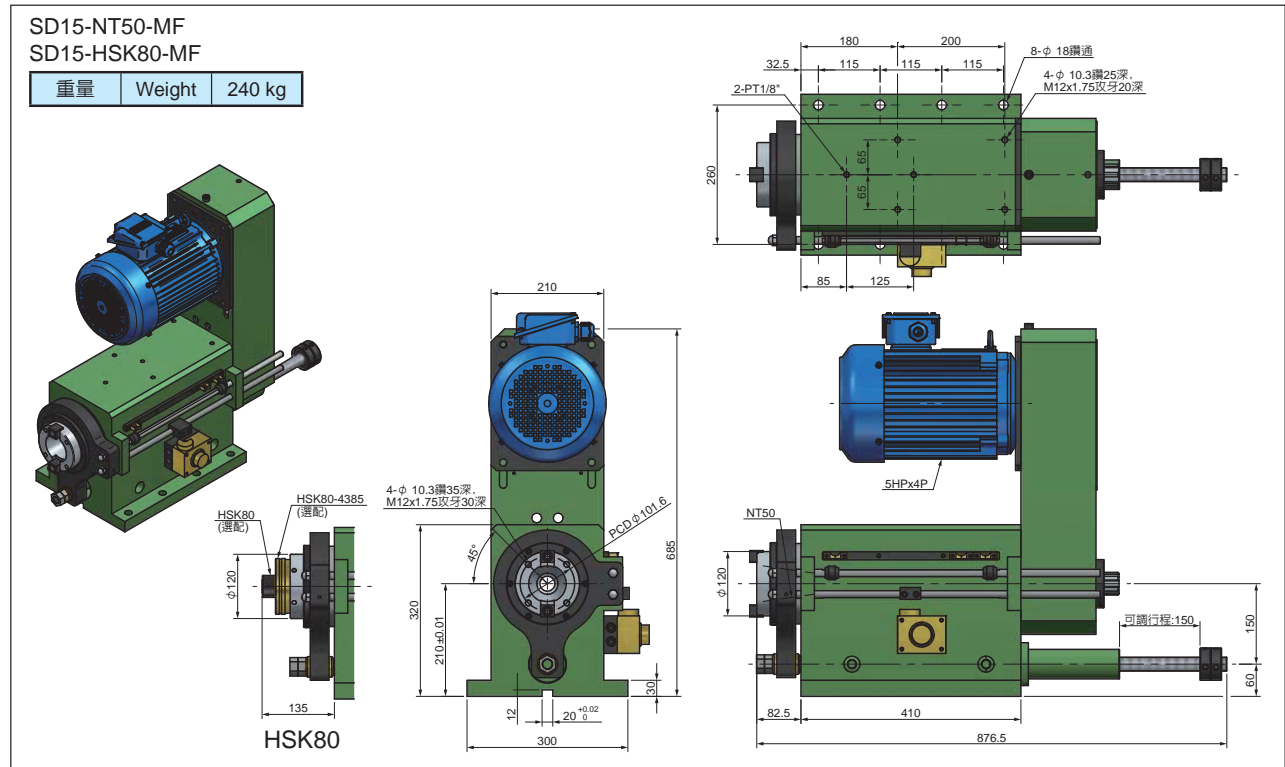



## 5076# ST0N-50 攻牙主軸頭 Tapping Head Units

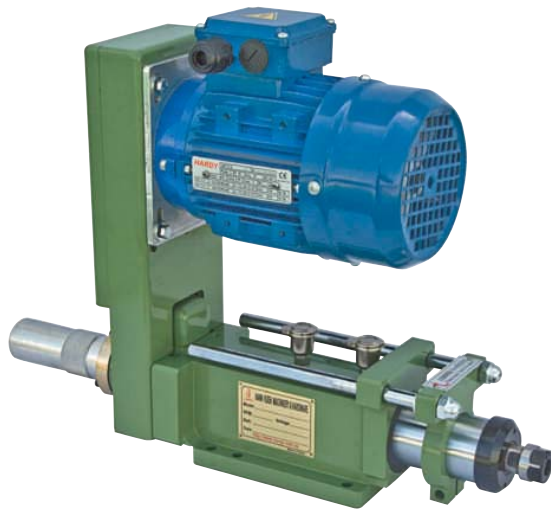

馬達盒組合



馬達盒組合

規格	Model	ST0N-50
攻牙能力	Tapping Capacity (S45C)	M6
最大行程	Max. Stroke	50 mm
螺旋導程	Thread Guide Pitch	0.25 ~ 1.25 mm
馬力	Horsepower, 3 Phase	1/2 HP , 220V/380V
總重	Net Weight	20 kg
主軸軸承	Spindle Bearing	6004ZZx3
皮帶輪軸承	Pulley Bearing	6906ZZx3
主軸油封	Spindle Seal	TC25x42x8 , TC50x62x10
傳動皮帶	Transmission Belt	5J - 240

Roundness:  $\leq 0.003\text{mm}$



# 5076# ST0N-50 攻牙主軸頭 Tapping Head Units

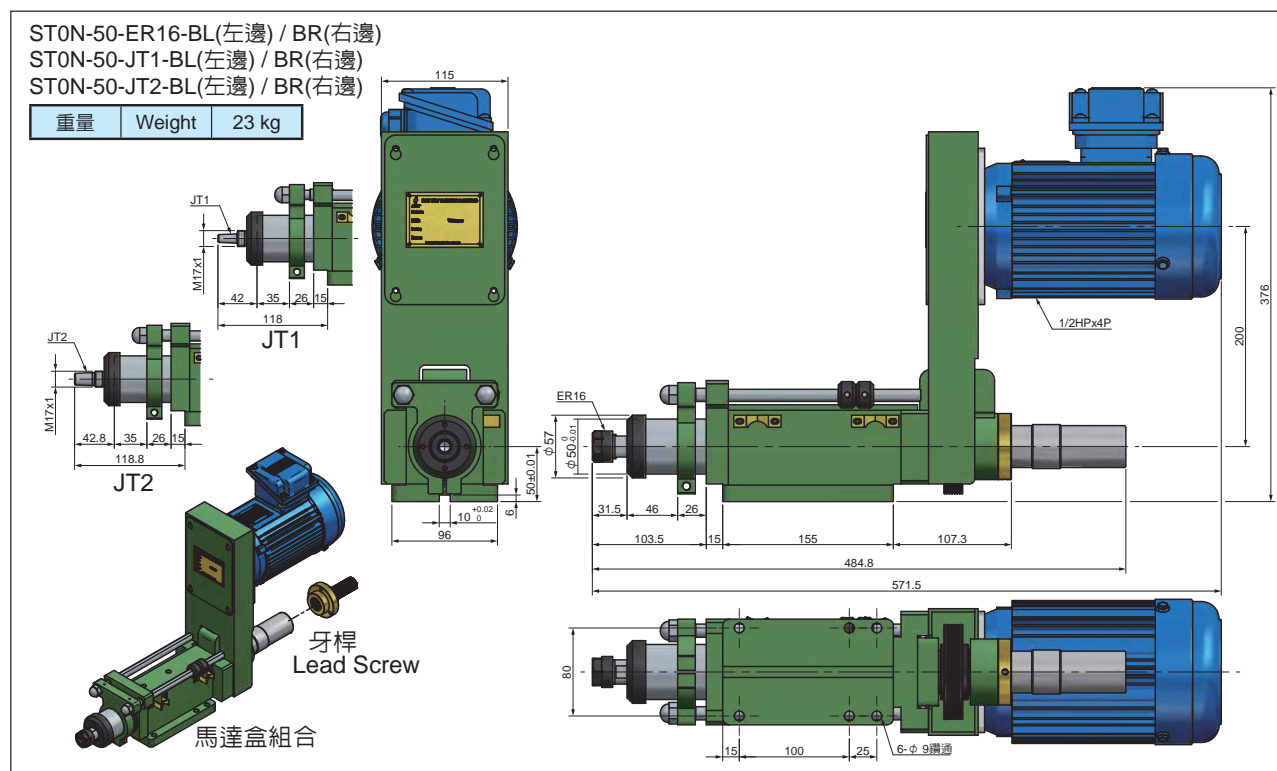
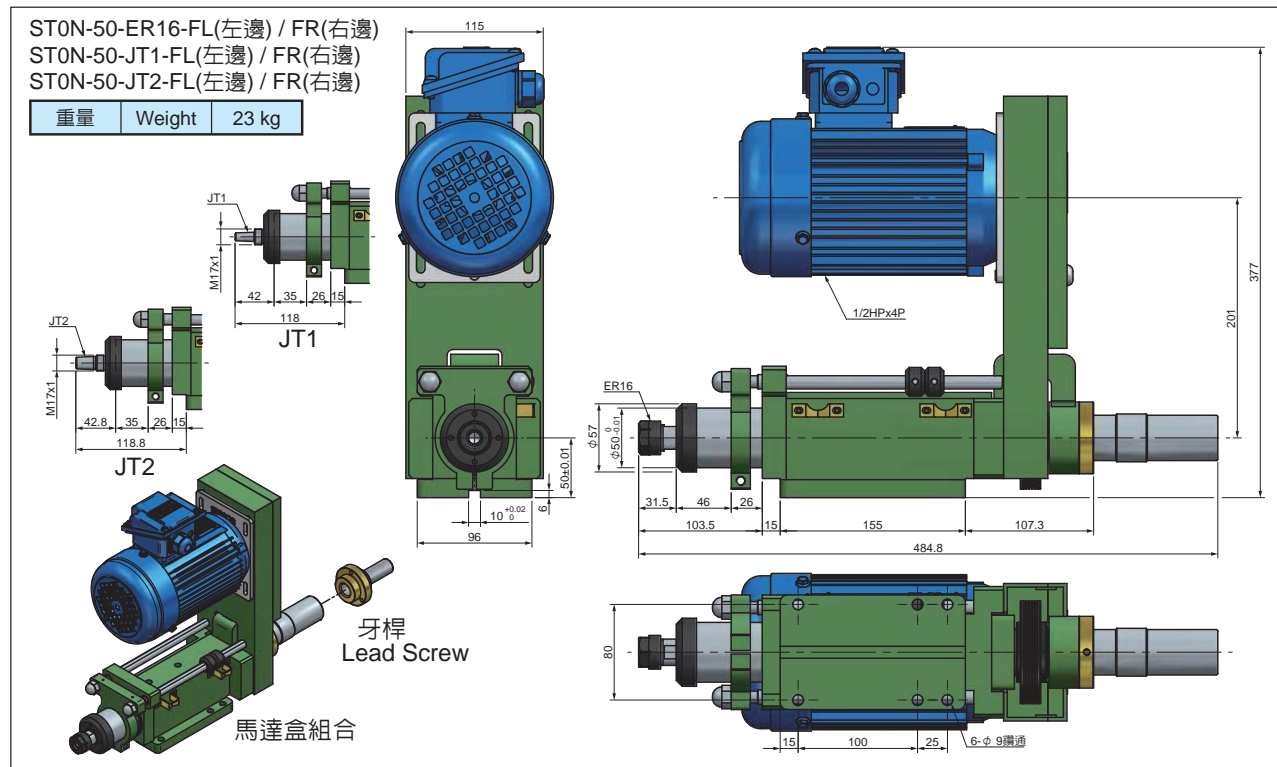

## 5077# ST1N-65 攻牙主軸頭 Tapping Head Units



馬達板型組合

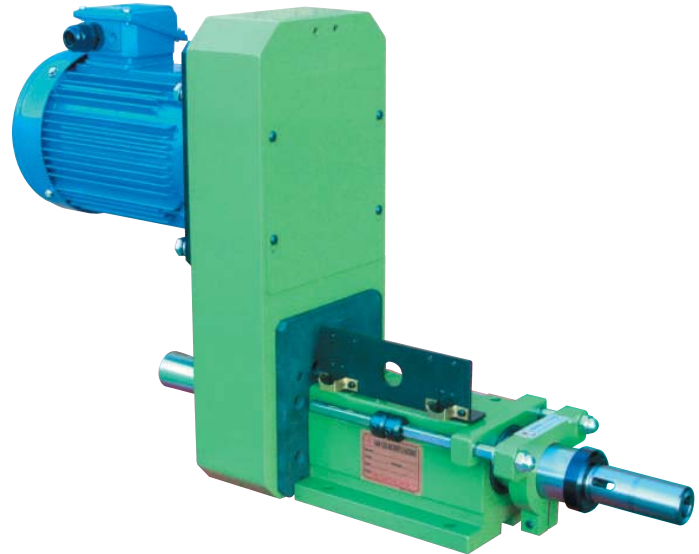

馬達盒組合

規格	Model	ST1N-65
攻牙能力	Tapping Capacity (S45C)	M12
最大行程	Max. Stroke	65 mm
螺旋導程	Thread Guide Pitch	0.4 ~ 2.0 mm
馬力	Horsepower, 3 Phase	1 HP , 220V/380V
總重	Net Weight	42 kg
主軸軸承	Spindle Bearing	6004ZZx3
皮帶輪軸承	Pulley Bearing	6006ZZx3
主軸油封	Spindle Seal	TC25x42x8 , TC50x62x10
傳動皮帶	Transmission Belt	A25x φ 125 , 8Mx47Tx33W

Roundness:  $\leq 0.003\text{mm}$





# 5077# ST1N-65 攻牙主軸頭 Tapping Head Units

ST1N-65-ER20-R(右向)-MF  
ST1N-65-ER20-L(左向)-MF

重量	Weight	39 kg
----	--------	-------

馬達盒組合

牙桿  
Lead Screw

ST1N-65-ER20-R(右向)-MB  
ST1N-65-ER20-L(左向)-MB

重量	Weight	39 kg
----	--------	-------

馬達盒組合

牙桿  
Lead Screw



# 5077# ST1N-65 攻牙主軸頭 Tapping Head Units

ST1N-65-ER20-AR(右向)  
ST1N-65-ER20-AL(左向)

重量	Weight	42 kg
----	--------	-------

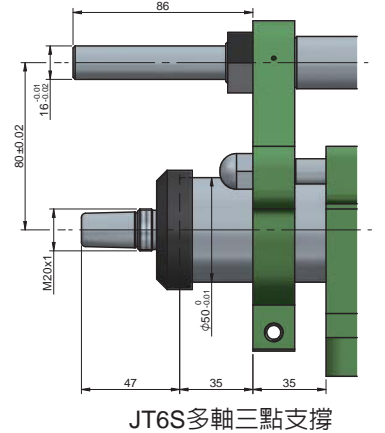
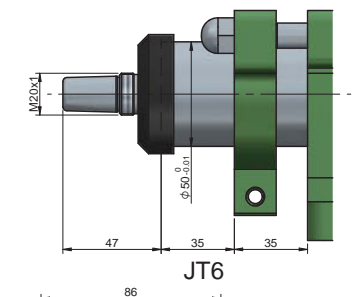
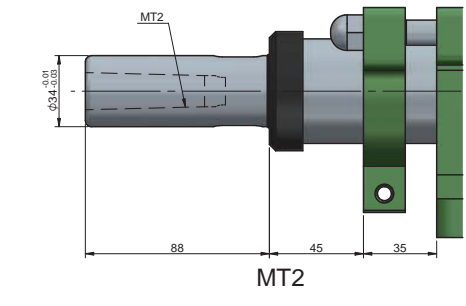
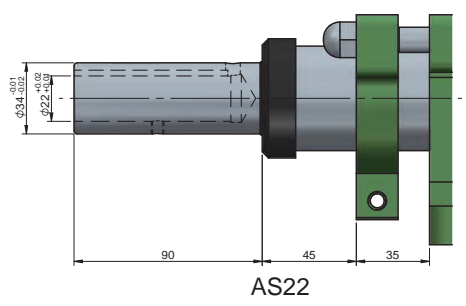
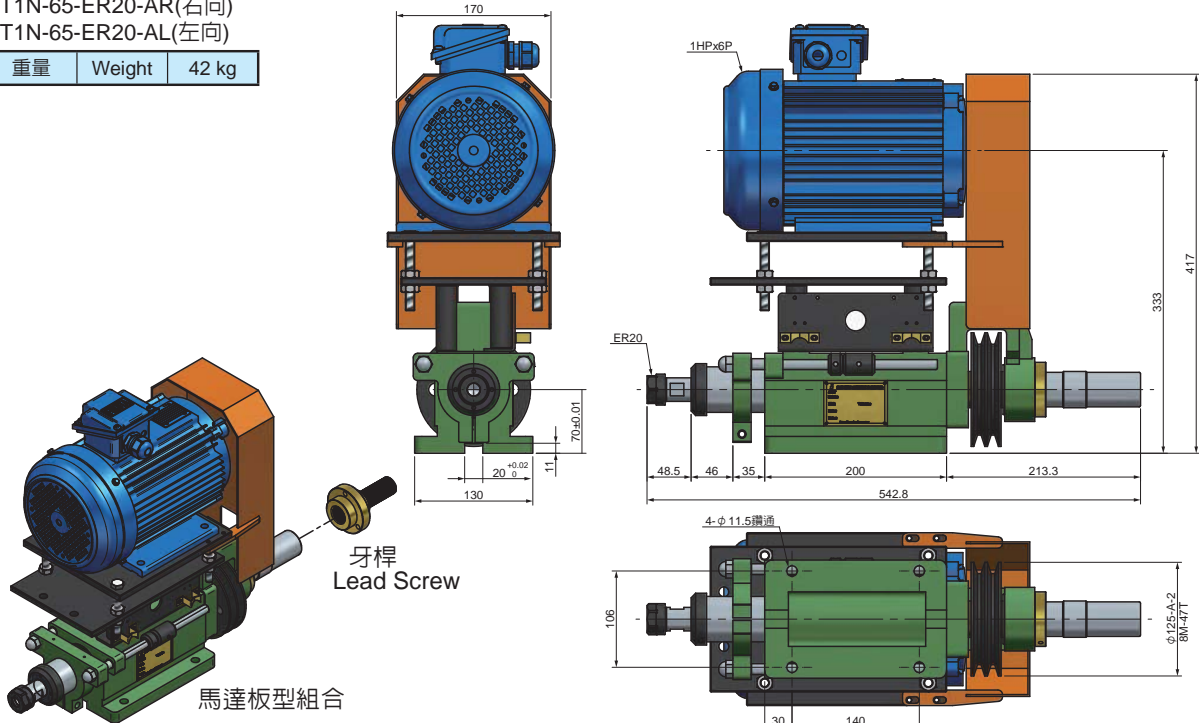

## 5078# ST2N-85 攻牙主軸頭 Tapping Head Units



馬達板型組合

規 格	Model	ST2N-85
攻牙能力	Tapping Capacity (S45C)	M30
最大行程	Max. Stroke	85 mm
螺旋導程	Thread Guide Pitch	0.7 ~ 2.5 mm
馬 力	Horsepower, 3 Phase	2 HP , 220V/380V
總 重	Net Weight	80 kg
主軸軸承	Spindle Bearing	6008ZZx3
皮帶輪軸承	Pulley Bearing	6010ZZx3
主軸油封	Spindle Seal	TC45x68x12 , TC75x95x13
傳動皮帶	Transmission Belt	A2x φ 150 , 8Mx58Tx34W

Roundness:  $\leq 0.003\text{mm}$





**HARDY**

## 5078# ST2N-85 攻牙主軸頭 Tapping Head Units

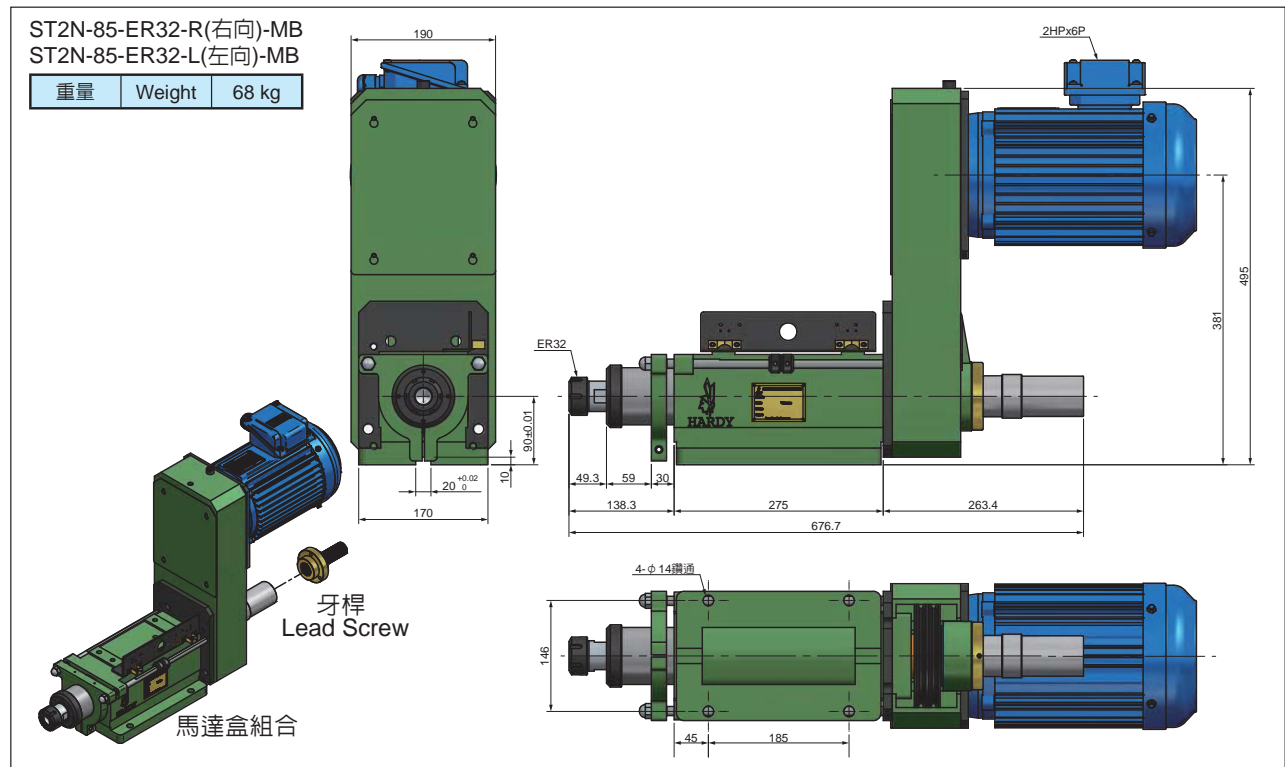
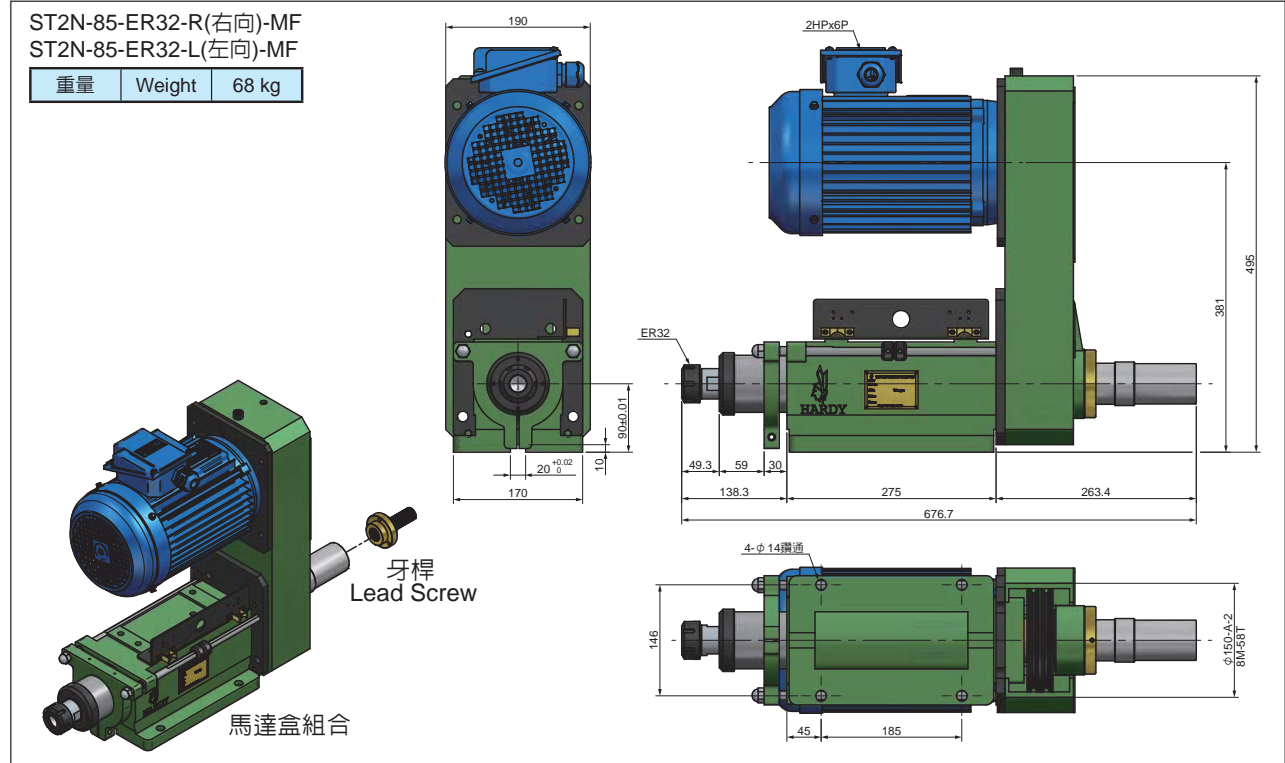



# 5078# ST2N-85 攻牙主軸頭 Tapping Head Units

ST2N-85-ER32-AR(右向)  
ST2N-85-ER32-AL(左向)

重量	Weight	80 kg
----	--------	-------

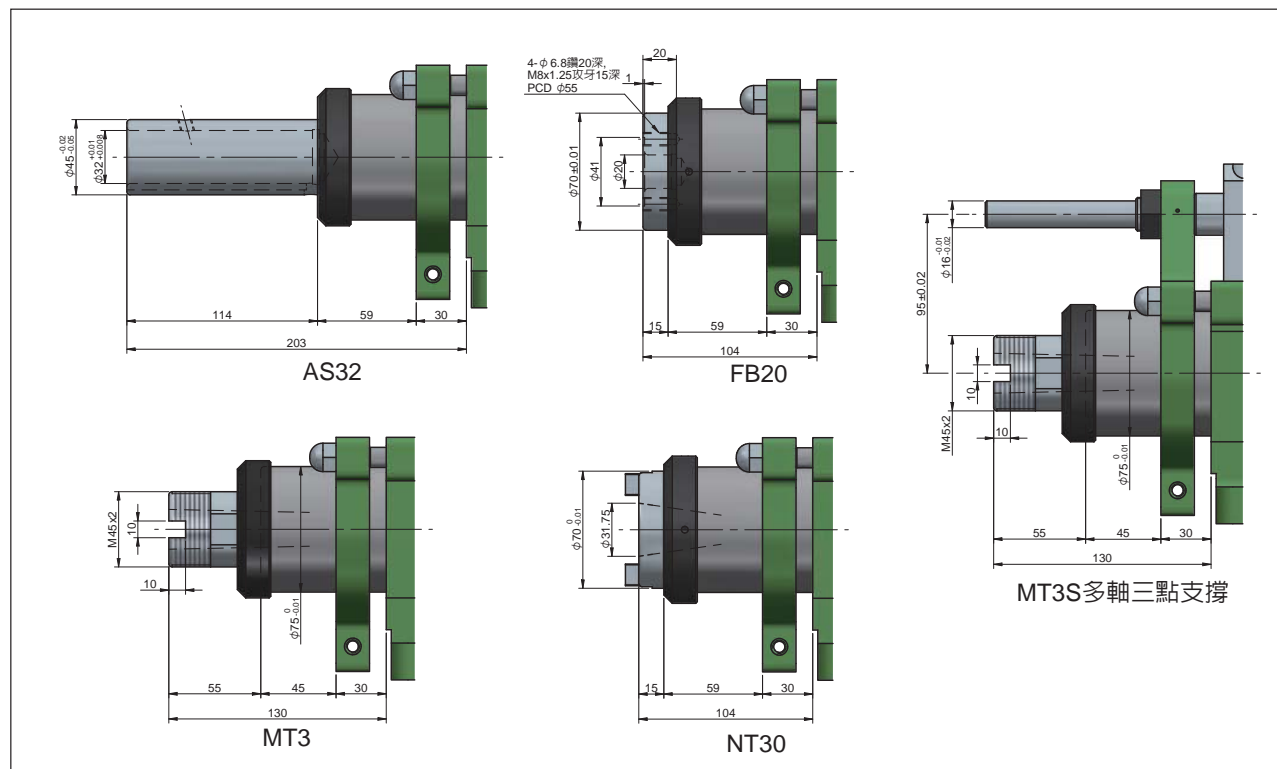
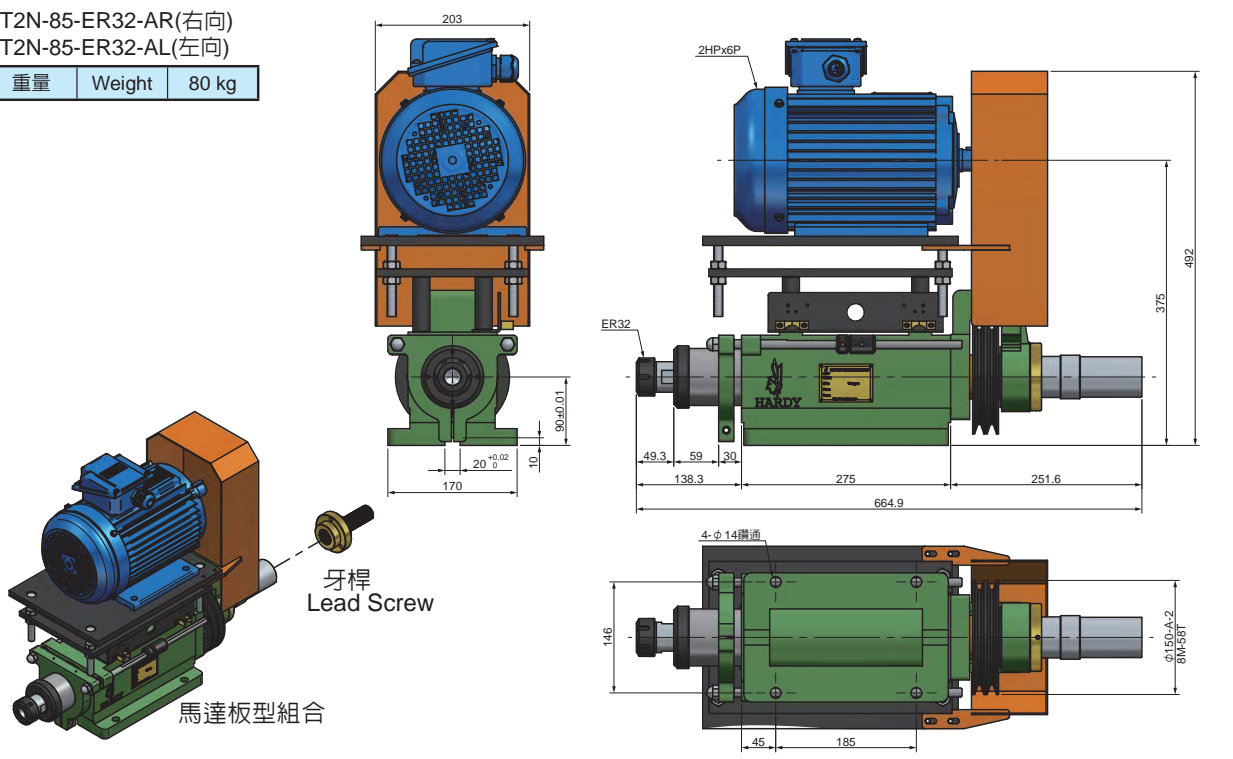

## 5079# ST3N-90 攻牙主軸頭 Tapping Head Units



馬達板型組合

規 格	Model	ST3N-90
攻牙能力	Tapping Capacity (S45C)	M45
最大行程	Max. Stroke	90 mm
螺旋導程	Thread Guide Pitch	0.8 ~ 3.0 mm
馬 力	Horsepower, 3 Phase	2 HP , 220V/380V
總 重	Net Weight	105 kg
主軸軸承	Spindle Bearing	6210ZZx3
皮帶輪軸承	Pulley Bearing	6212ZZx2
主軸油封	Spindle Seal	TC60×90×10 , TC100×125×12 TC70×92×10
傳動皮帶	Transmission Belt	8M×48T×40W , RS40-2列-30T

Roundness:  $\leq 0.003\text{mm}$



# 5079# ST3N-90 攻牙主軸頭 Tapping Head Units

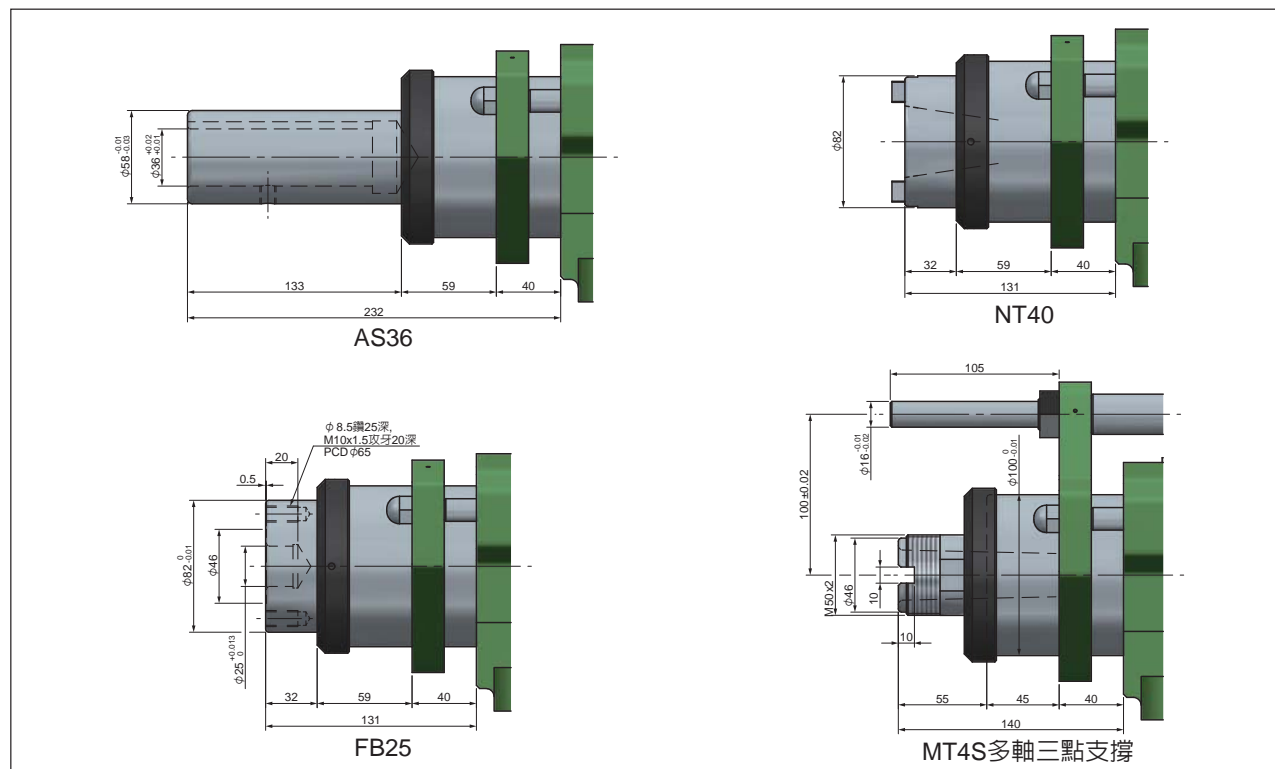
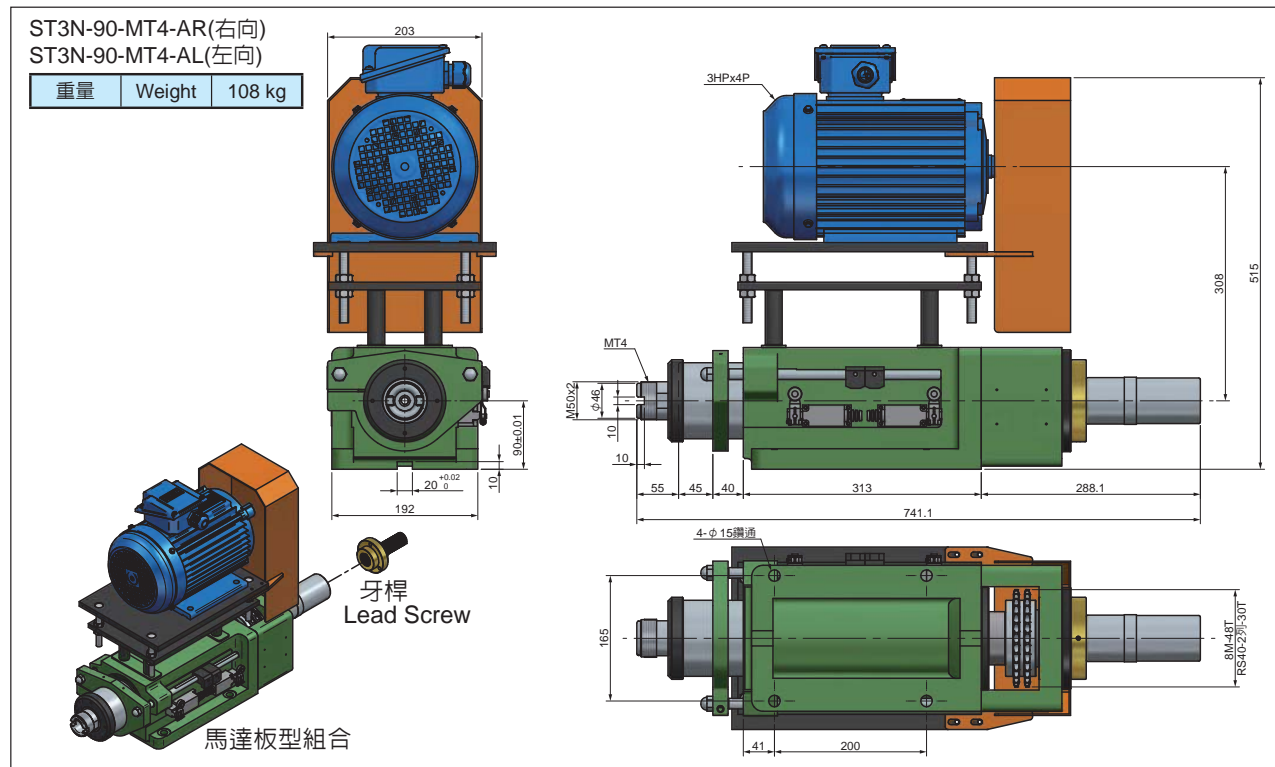



## 5080# D51N 鑽孔/攻牙雙主軸頭 Drilling / Tapping Twin Head Units

規 格	Model	SD5-85
鑽孔能力	Drilling Capacity (S45C)	φ 13 mm
最大行程	Max. Stroke	85 mm
最高轉速	Max. RPM	5000 RPM
推進壓力	Propel Pressure	空壓 (A) 4~8 kg/cm <sup>2</sup> 油壓 (H) 20~25 kg/cm <sup>2</sup>
氣缸面積	Cylinder Diameter	前進 (F) 21.5 cm <sup>2</sup> 後退 (B) 11.5 cm <sup>2</sup>
馬 力	Horsepower, 3 Phase	1 HP, 220V / 380V
傳動皮帶	Transmission Belt	5M - 615
總 重	Net Weight	38 kg
主軸軸承	Spindle Bearing	6004ZZx4
皮帶輪軸承	Pulley Bearing	6203ZZx3
前蓋油封	Front Cover Seal	DKB 50x62x10
活塞O型環	Piston O-ring	油壓AS-53x3, 空壓UHS53
前蓋O型環	Front Cover O-ring	AG-58x2, AP-50x2, AG-68x1
後蓋油封	Back Cover Seal	TC35x45x8
後蓋O型環	Back Cover O-ring	AG-58x2, CPU-35x45x6

Roundness: ≤ 0.003mm

規 格	Model	ST1N-65
攻牙能力	Tapping Capacity (S45C)	M12
最大行程	Max. Stroke	65 mm
螺旋導程	Thread Guide Pitch	0.4 ~ 2.0 mm
馬 力	Horsepower, 3 Phase	1 HP, 220V/380V
總 重	Net Weight	42 kg
主軸軸承	Spindle Bearing	6004ZZx3
皮帶輪軸承	Pulley Bearing	6006ZZx3
主軸油封	Spindle Seal	TC25x42x8, TC50x62x10
傳動皮帶	Transmission Belt	A25xφ 125, 8Mx47Tx33W

Roundness: ≤ 0.003mm

5080# D51N 鑽孔/攻牙雙主軸頭  
Drilling / Tapping Twin Head Units

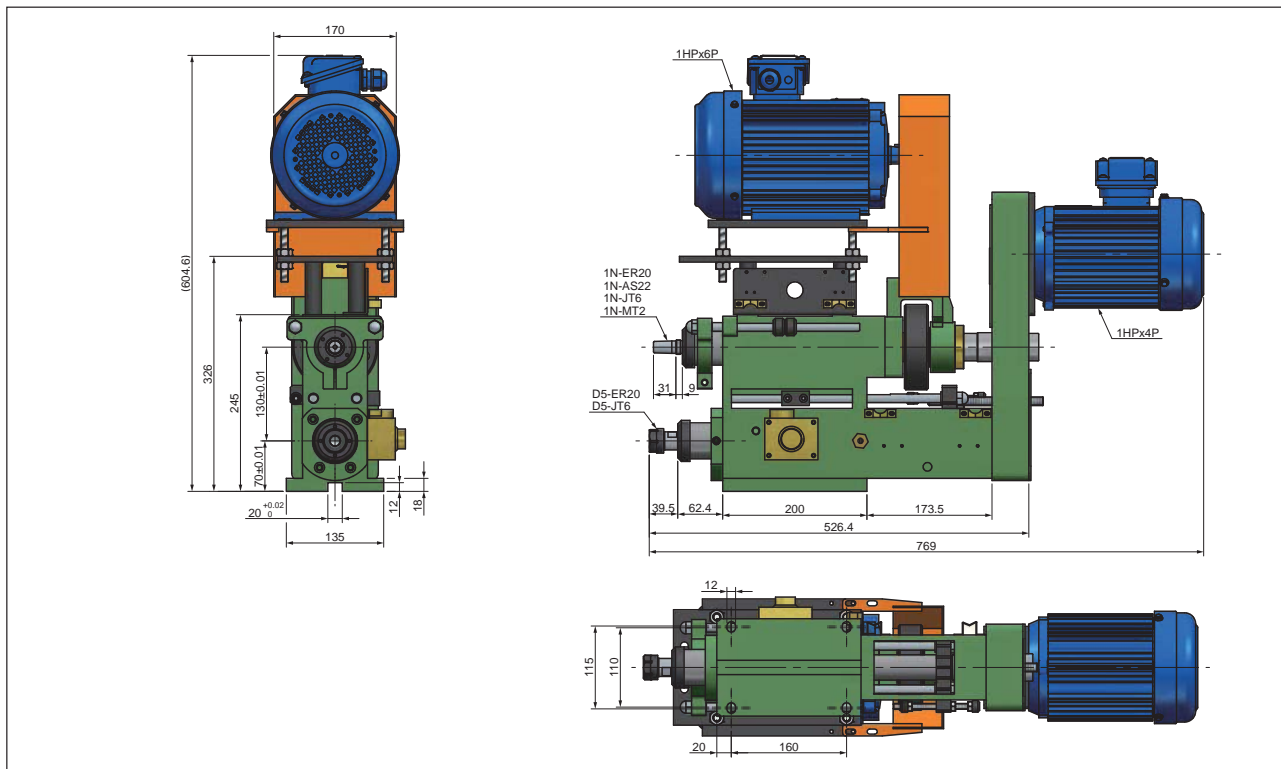
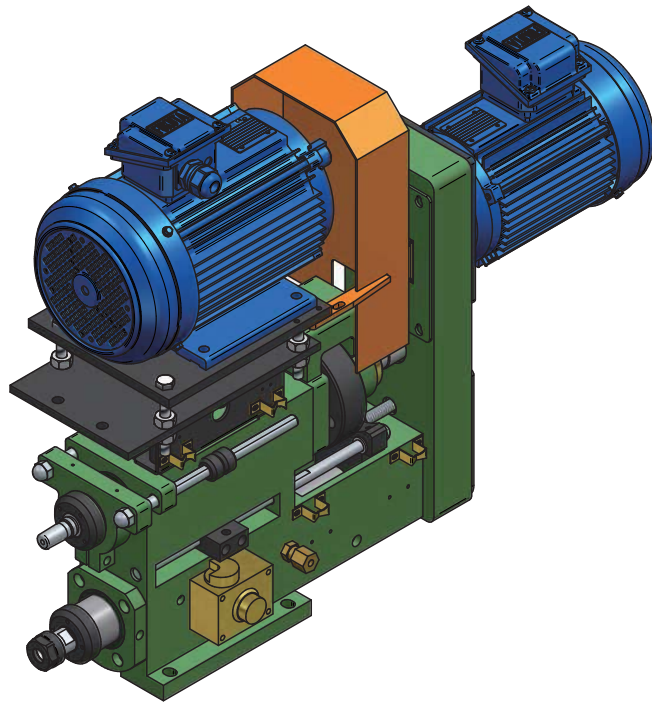





**HARDY**

**翰坤五金機械公司**

http://www.hardy-tw.com  
TEL : 886-4-24860602  
FAX : 886-4-24860605

- S,SR 搪銑主軸頭
- SD 鑽孔主軸頭
- ST 攻牙主軸頭

**訂購明細表**

公司名稱		聯絡人	
電話		傳真	
地址			

- 一、規格：\_\_\_\_\_ 主軸型式：\_\_\_\_\_ 數量：\_\_\_\_\_
- 二、推送方式： 空壓  油壓  伺服馬達/中心拉桿： 公制  英制
- 三、加工： 鑽孔  攻牙  搪孔  銑面  其他\_\_\_\_\_
- 四、加工材質：\_\_\_\_\_ 直徑：\_\_\_\_\_  $\phi$  深度：\_\_\_\_\_ 轉速：\_\_\_\_\_  
絲攻牙距：\_\_\_\_\_ 刀具材質： 高速鋼  硬質鎢鋼
- 五、主軸馬達： 三相感應馬達  減速機  伺服馬達  
\_\_\_\_\_HP (kW) \_\_\_\_\_P(Pole) \_\_\_\_\_V(電壓) \_\_\_\_\_Hz (頻率)
- 六、進給伺服馬達：\_\_\_\_\_kW \_\_\_\_\_V (需附圖)
- 七、展刀伺服馬達：\_\_\_\_\_kW \_\_\_\_\_V (需附圖)
- 八、皮帶輪傳動： 時規  三角  山型  其他\_\_\_\_\_
- 九、附件： 馬達盒  馬達板型  馬達含煞車  多軸定位孔  
 微動開關  進接開關

左向流量閥  \_\_\_\_\_ 台

左向近接,微動開關  \_\_\_\_\_ 台

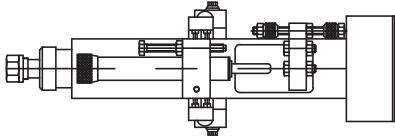

右向流量閥  \_\_\_\_\_ 台

右向近接,微動開關  \_\_\_\_\_ 台

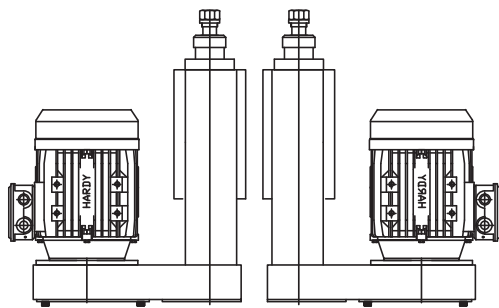

前置馬達  \_\_\_\_\_ 台

右側90°  \_\_\_\_\_ 台

後置馬達  \_\_\_\_\_ 台

前置馬達  \_\_\_\_\_ 台

左側90°  \_\_\_\_\_ 台

後置馬達  \_\_\_\_\_ 台

馬達配置方向

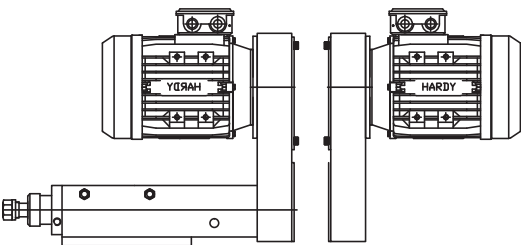

上方,前置馬達 \_\_\_\_\_ 台

上方,後置馬達 \_\_\_\_\_ 台

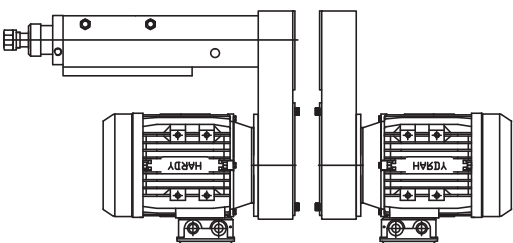

下方,前置馬達 \_\_\_\_\_ 台

下方,後置馬達 \_\_\_\_\_ 台



HANN KUEN MACHINERY&HARDWARE  
 http://www.hardy-tw.com  
 TEL : 886-4-24860602  
 FAX : 886-4-24860605

- S,SR Boring&Milling Head Unit
- SD Drilling Head Unit
- ST Tapping Head Unit

**HARDY**

Order Form

Company		Contact With	
Tel		Fax	
Address			

- I . Model: \_\_\_\_\_ Spindle Taper \_\_\_\_\_ Quantity \_\_\_\_\_
- II . Propel:  Pneumatic  Hydraulic  Servo Motor / Draw Bar:  Metric  Inch
- III . Cutting:  Drilling  Tapping  Boring  Milling  Other \_\_\_\_\_
- IV . Cutting Material: \_\_\_\_\_ Diameter \_\_\_\_\_  $\phi$  Depth \_\_\_\_\_ RPM \_\_\_\_\_  
 Tap Pitch \_\_\_\_\_ Cutter Material:  High Speed Steel  Carbide Tip
- V . Spindle Motor:  3-Phase AC Induction  Gear Reducer  Servo Motor  
 \_\_\_\_\_HP (kW) \_\_\_\_\_P (Pole) \_\_\_\_\_V (Voltage) \_\_\_\_\_Hz (Frequency)
- VI . Feeding Servo Motor: \_\_\_\_\_kW \_\_\_\_\_V (drawing required)
- VII . Facing Head Servo Motor: \_\_\_\_\_kW \_\_\_\_\_V (drawing required)
- VIII . Transmission:  Timing Belt  V Belt  Poly-V Belt  Other \_\_\_\_\_
- IX . Accessories:  Motor Stand  Motor Plates  Motor with brake  Guide Rod  
 Limit Switch  Proximity Sensor

Left Fluid Control  \_\_\_\_\_ pcs  
 Left Limit Switch or Proximity Sensor  \_\_\_\_\_ pcs

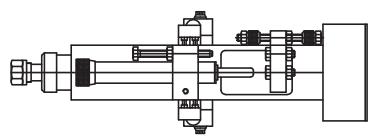

Right Fluid Control  \_\_\_\_\_ pcs  
 Right Limit Switch or Proximity Sensor  \_\_\_\_\_ pcs

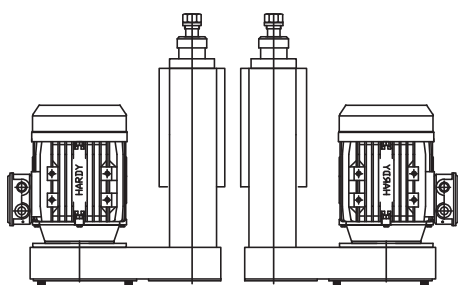

Right90° Front  \_\_\_\_\_ pcs  
 Back  \_\_\_\_\_ pcs  
 Left90° Front  \_\_\_\_\_ pcs  
 Back  \_\_\_\_\_ pcs

Motor Direction

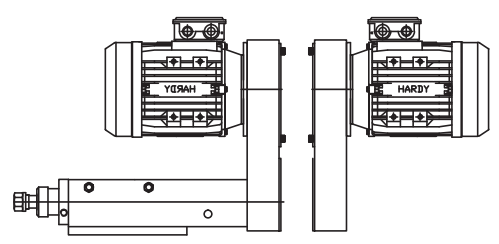

Upside,Front \_\_\_\_\_ pcs  
 Upside,Back \_\_\_\_\_ pcs

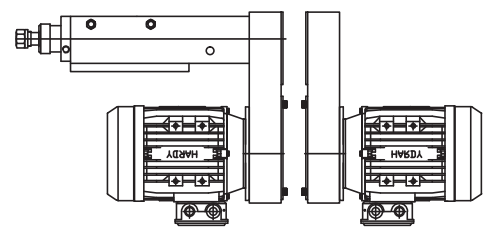

Bottom,Front \_\_\_\_\_ pcs  
 Bottom,Back \_\_\_\_\_ pcs