

5032# S25 搪銑主軸頭 Boring & Milling Head Unit

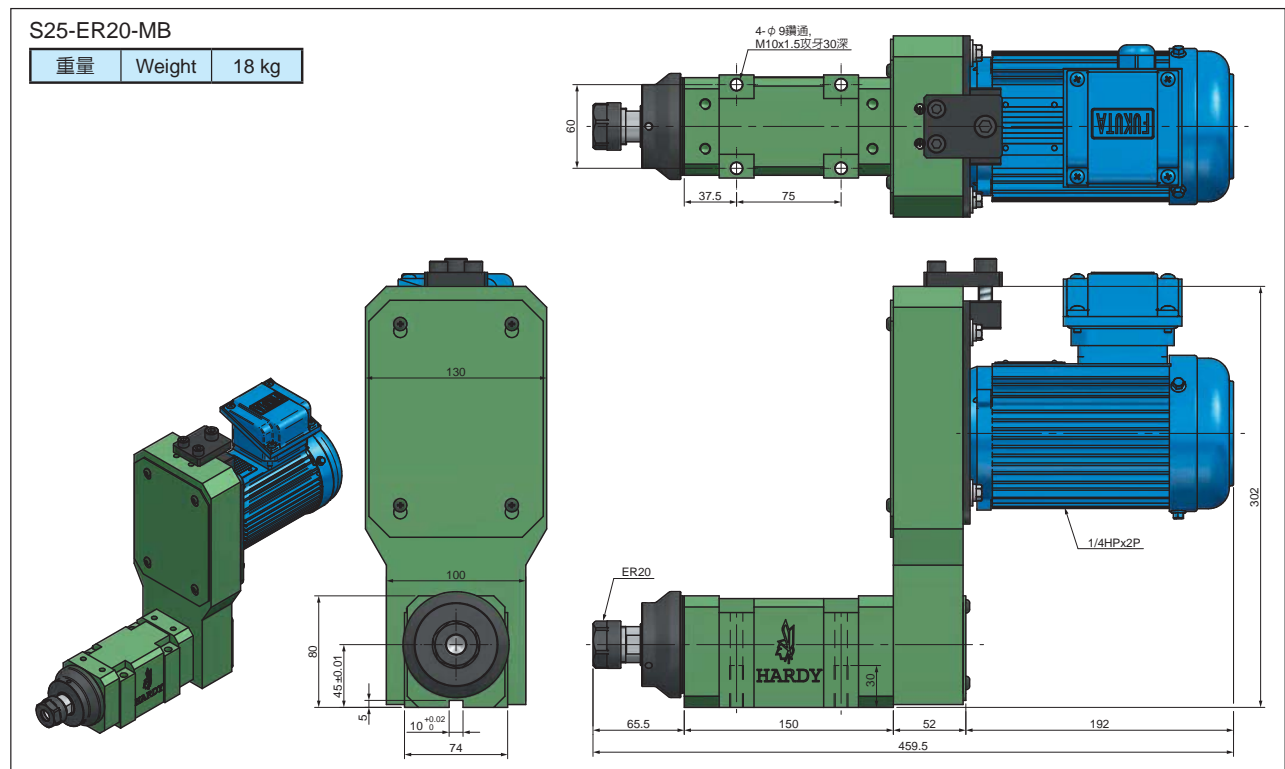

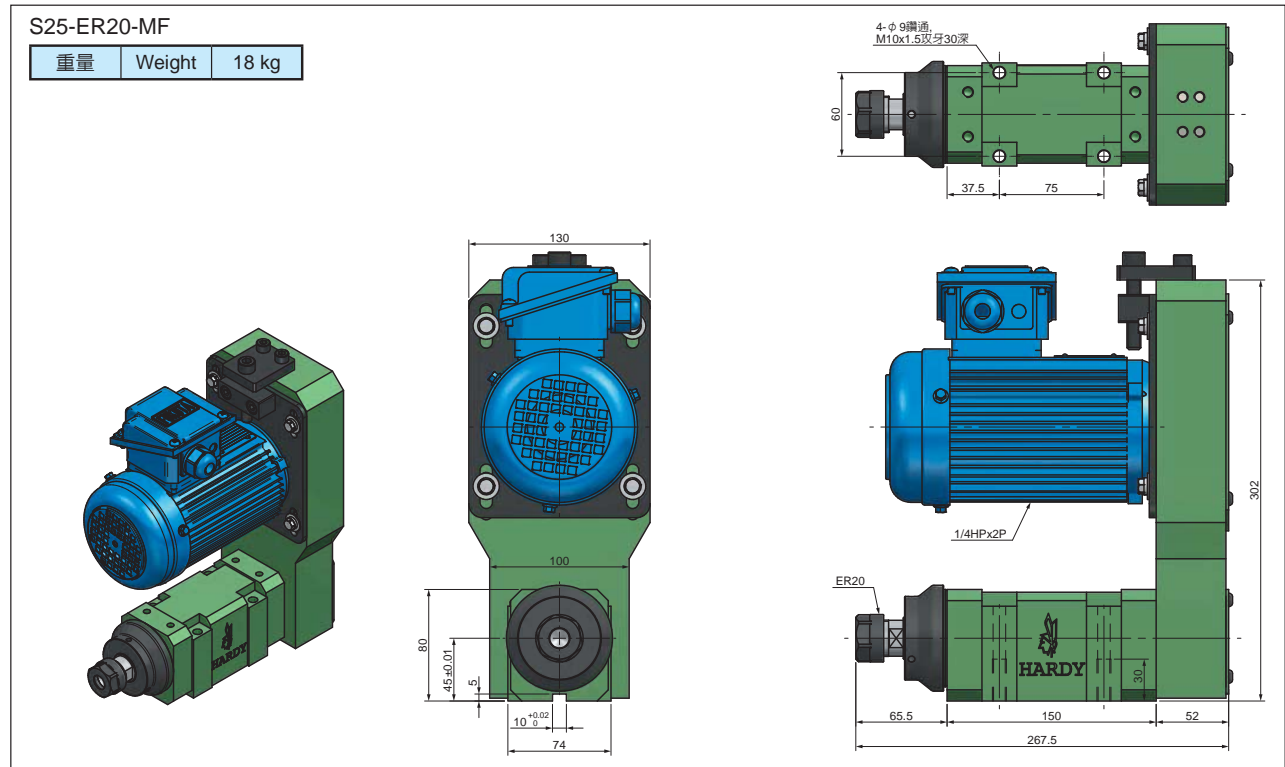

HARDY

5033# S35 搪銑主軸頭 Boring & Milling Head Unit

規格	Model	S35	S35H
主軸	Spindle	MT3 or ER32	
最高轉速	Max. RPM	3000	10000
軸承	Bearing	32007 / 6007Z 32006 / 6006Z	7007x2 7006x2
真圓度	Roundness	Within 0.003mm 內	
最大動力	Max. Power	Within 1 HP 內	
溫升	Rising Temperature	Within 20°C 內	

★出廠附精度檢驗表

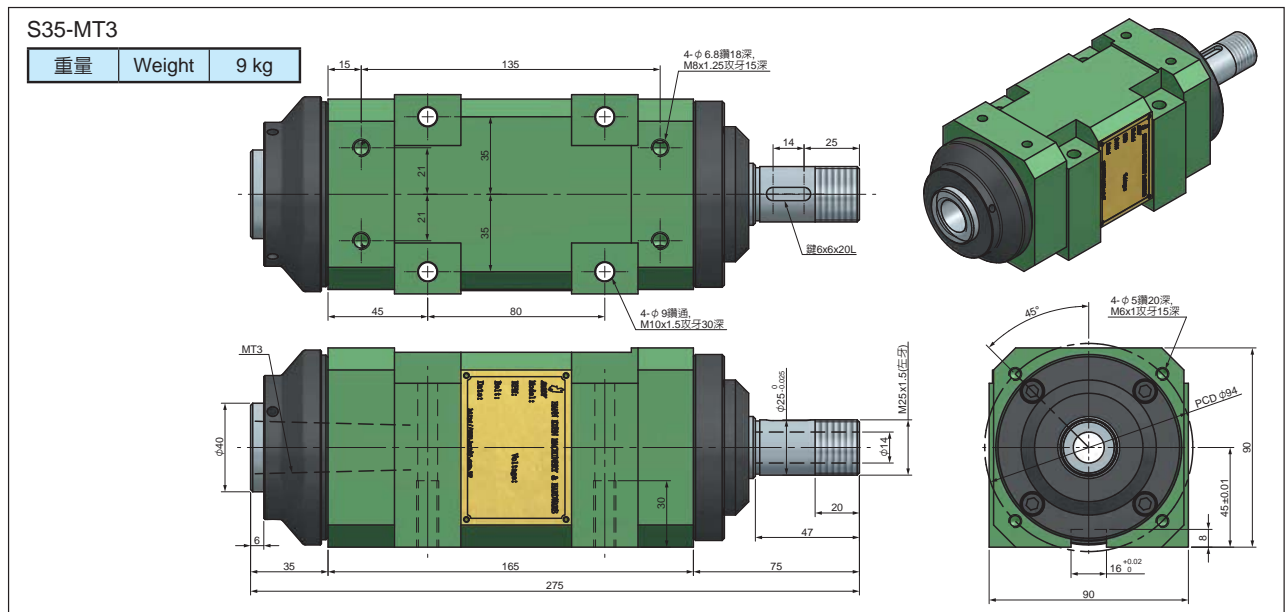
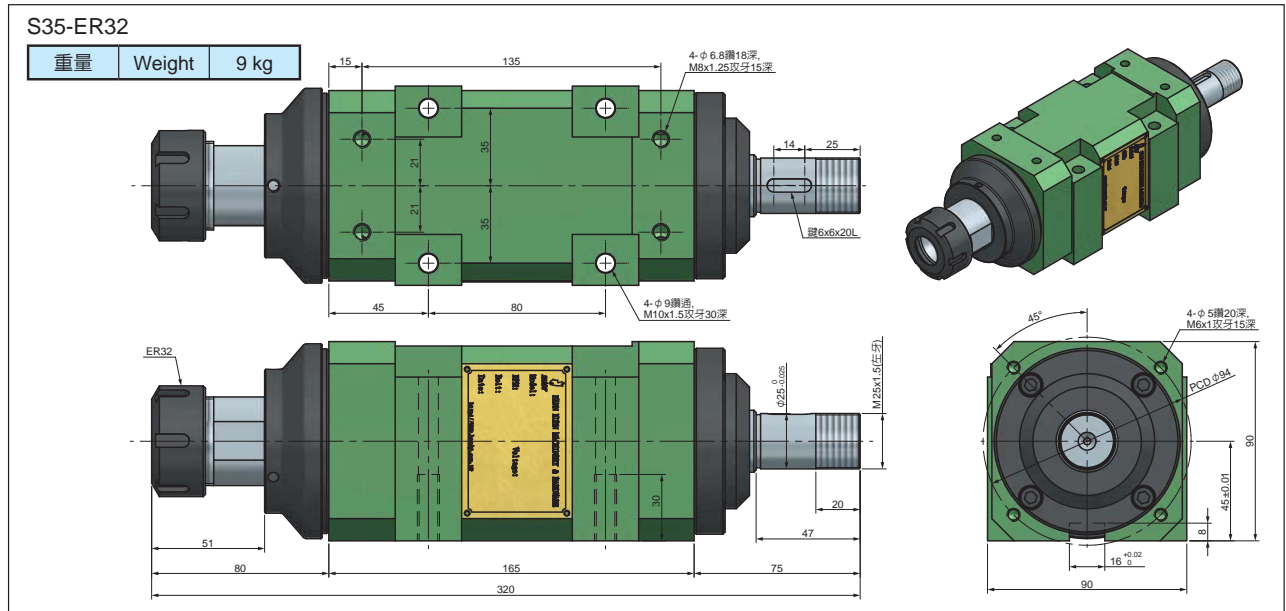

5034# S45 搪銑主軸頭 Boring & Milling Head Unit

S45-ER40-MF
S45-NT30-MF

重量	Weight	45 kg
----	--------	-------

S45-ER40-MB
S45-NT30-MB

重量	Weight	45 kg
----	--------	-------



5035# S55 搪銑主軸頭 Boring & Milling Head Unit

規格	Model	S55	S55H
主軸	Spindle	NT40 or MT4	
最高轉速	Max. RPM	2000	6000
軸承	Bearing	32011 / 6011Z 32010 / 6010Z	7011x2 7010x2
真圓度	Roundness	Within 0.003mm 內	
最大動力	Max. Power	Within 3 HP 內	
溫升	Rising Temperature	Within 20°C 內	

★出廠附精度檢驗表

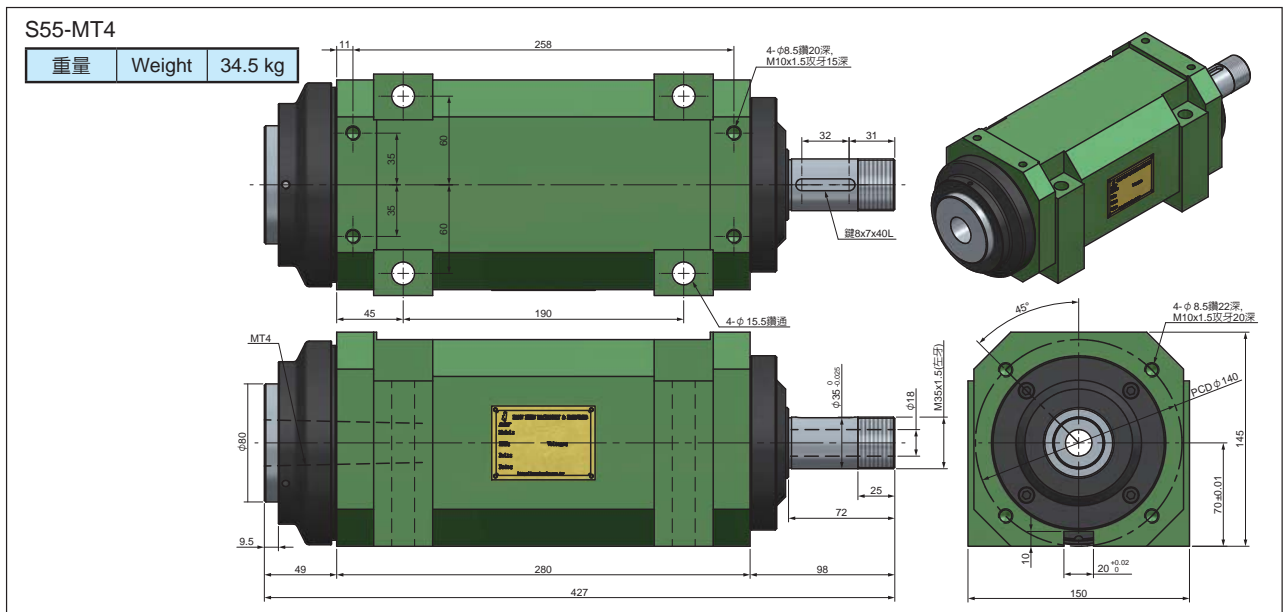
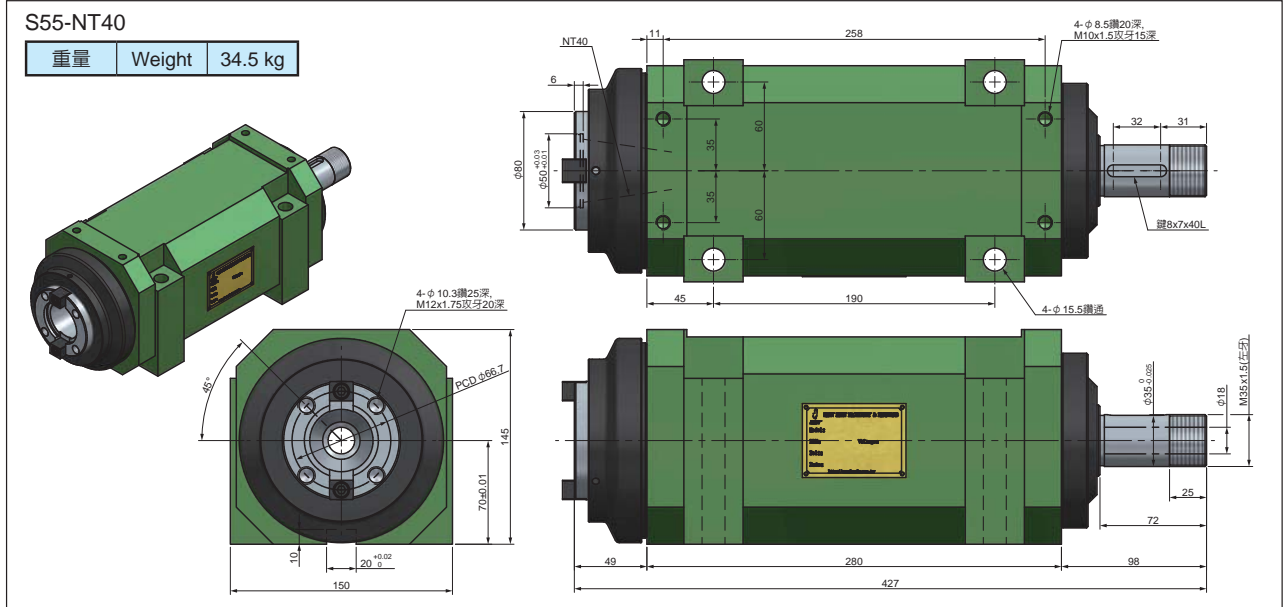

5035# S55 搪銑主軸頭 Boring & Milling Head Unit

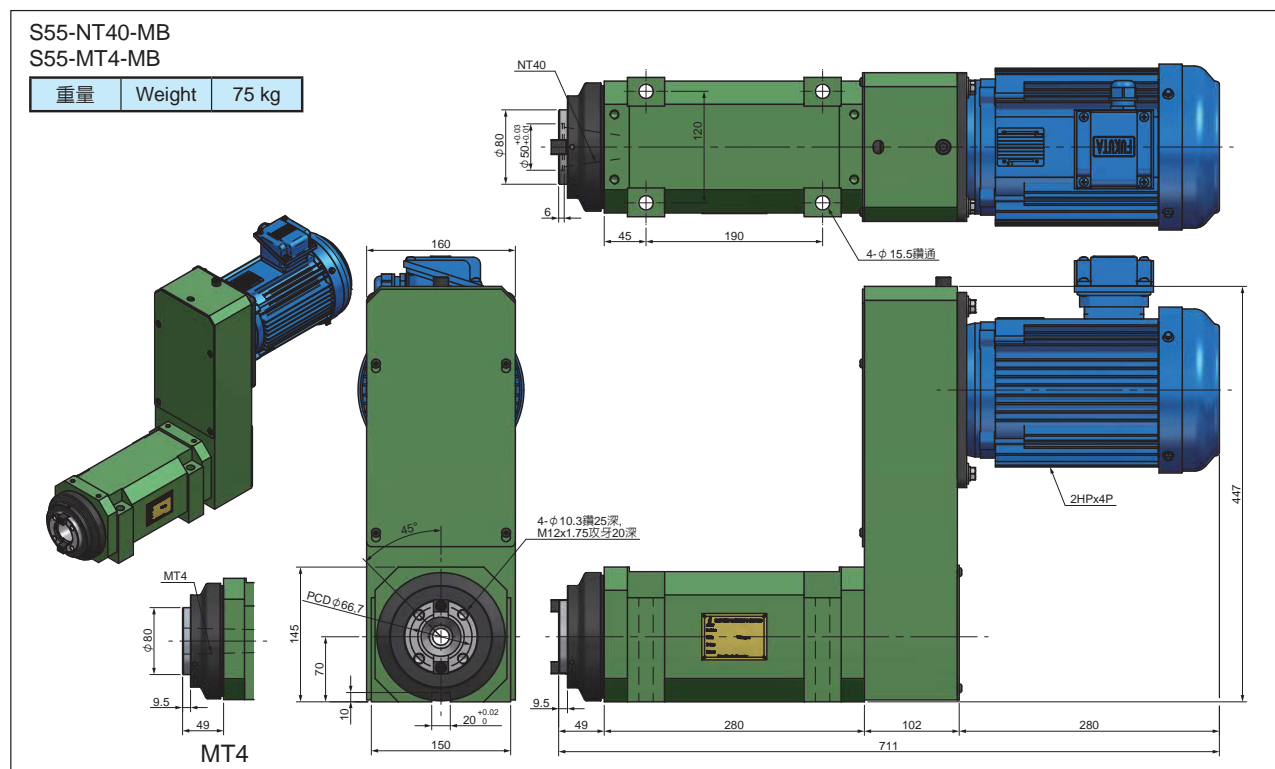
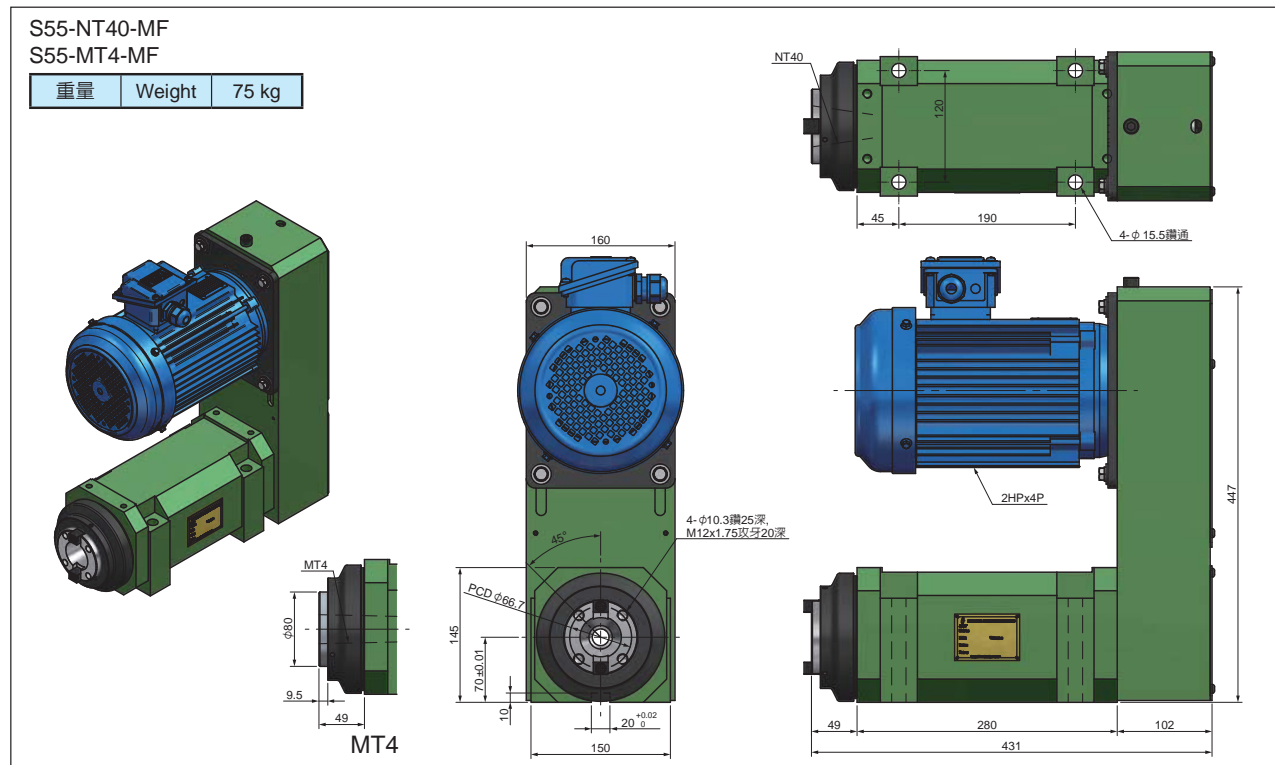



5036# S60 搪銑主軸頭 Boring & Milling Head Unit

規格	Model	S60	S60H
主軸	Spindle	NT40 or A2-4 or FB50	
最高轉速	Max. RPM	1800	5000
軸承	Bearing	32211 / 6211Z 32212 / 6212Z	7211x2 7212x2
真圓度	Roundness	Within 0.003mm 內	
最大動力	Max. Power	Within 5 HP 內	
溫升	Rising Temperature	Within 20°C 內	

★出廠附精度檢驗表

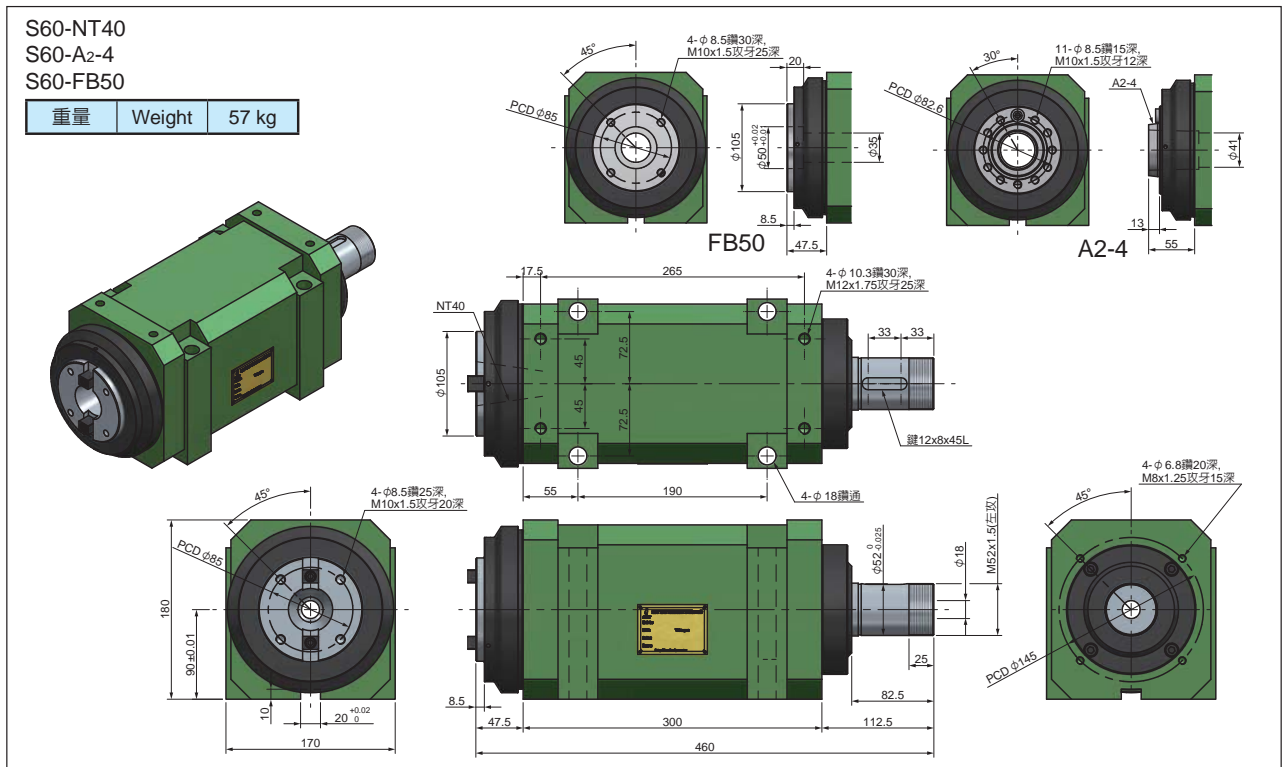



5036# S60 搪銑主軸頭 Boring & Milling Head Unit

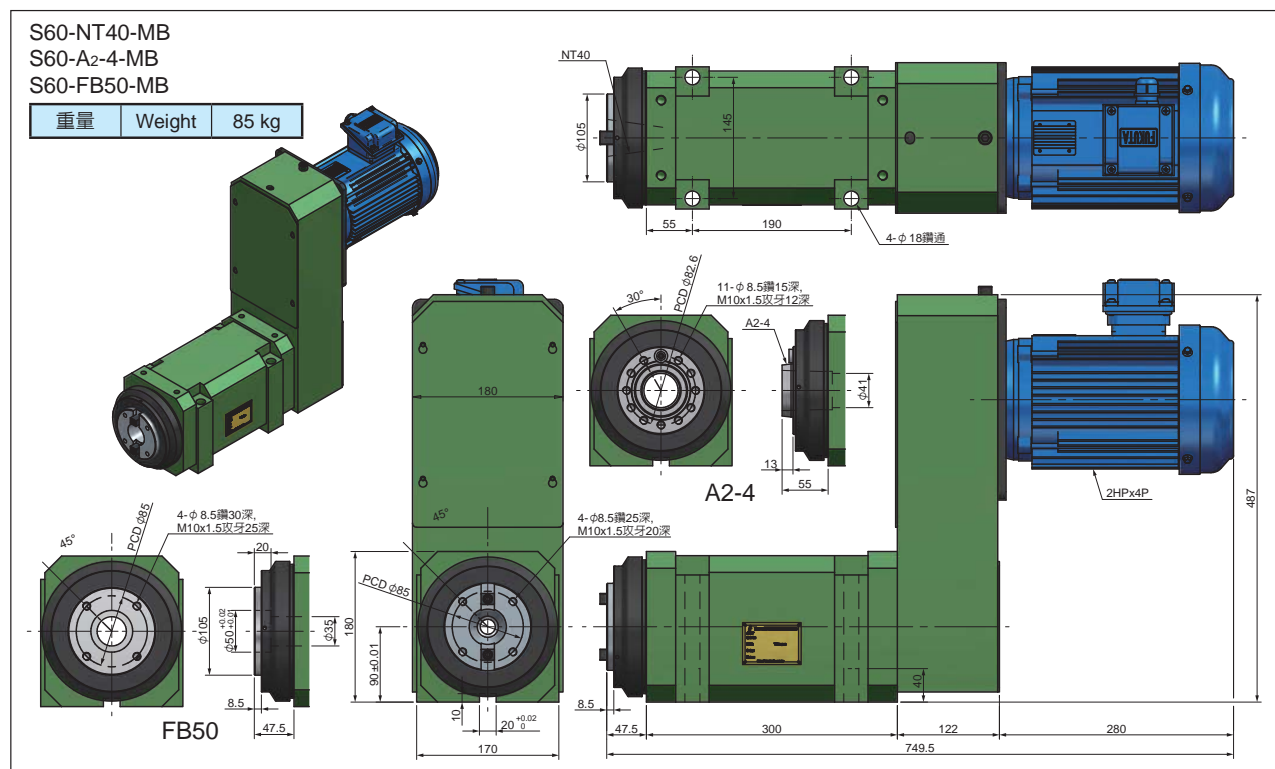
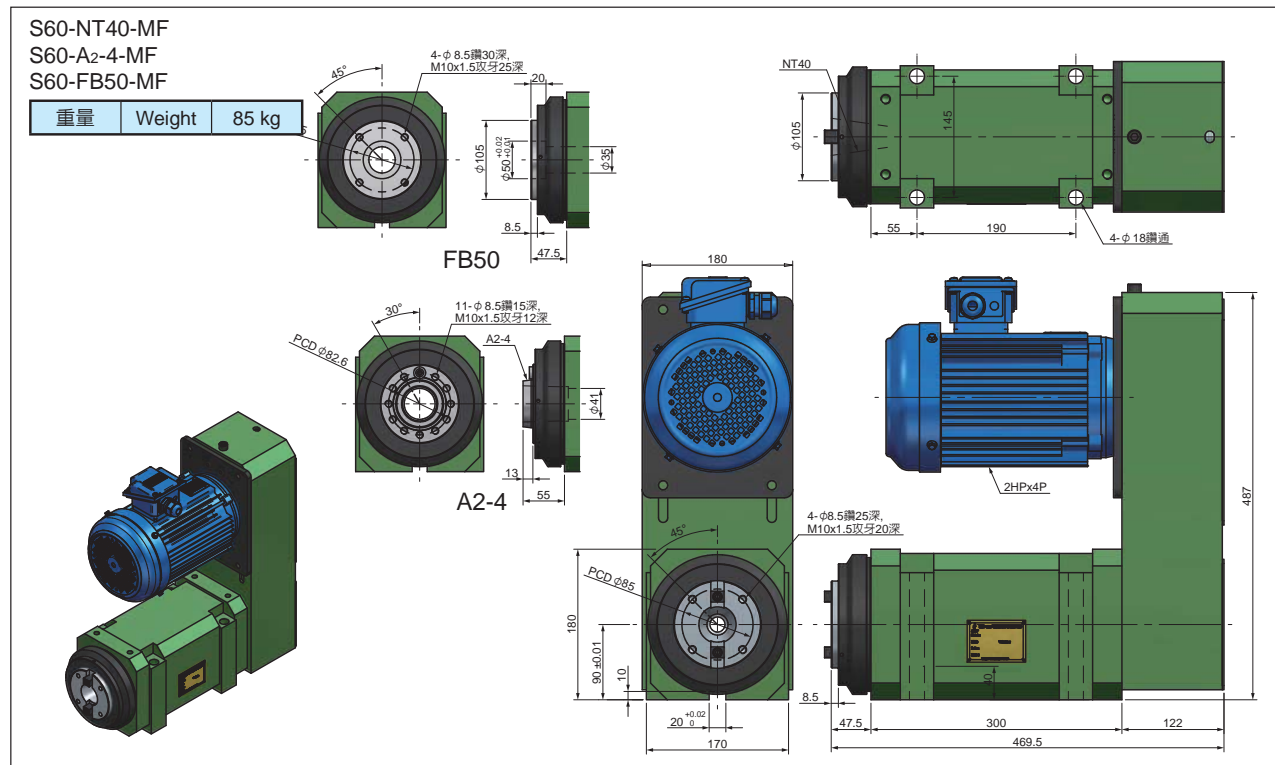



5037# S75 搪銑主軸頭 Boring & Milling Head Unit

規格	Model	S75	S75H
主軸	Spindle	NT50 or FB75	
最高轉速	Max. RPM	1600	4000
軸承	Bearing	32015 / 6015Z 32014 / 6014Z	7015x2 7014x2
真圓度	Roundness	Within 0.003mm 內	
最大動力	Max. Power	Within 5 HP 內	
溫升	Rising Temperature	Within 20°C 內	

★出廠附精度檢驗表

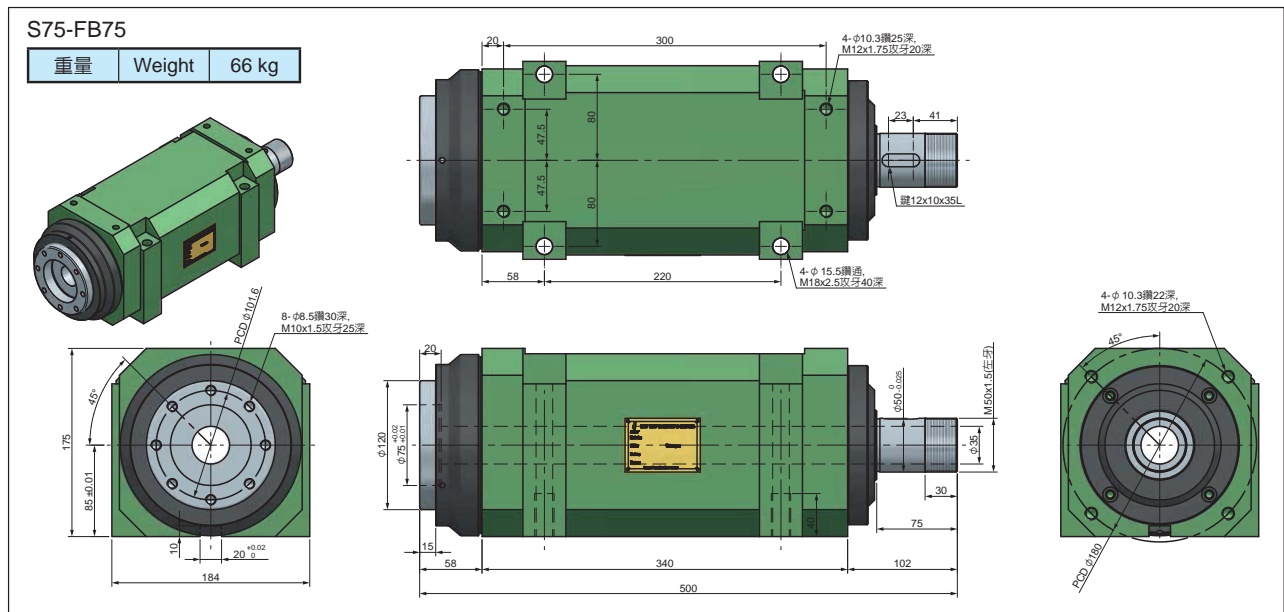
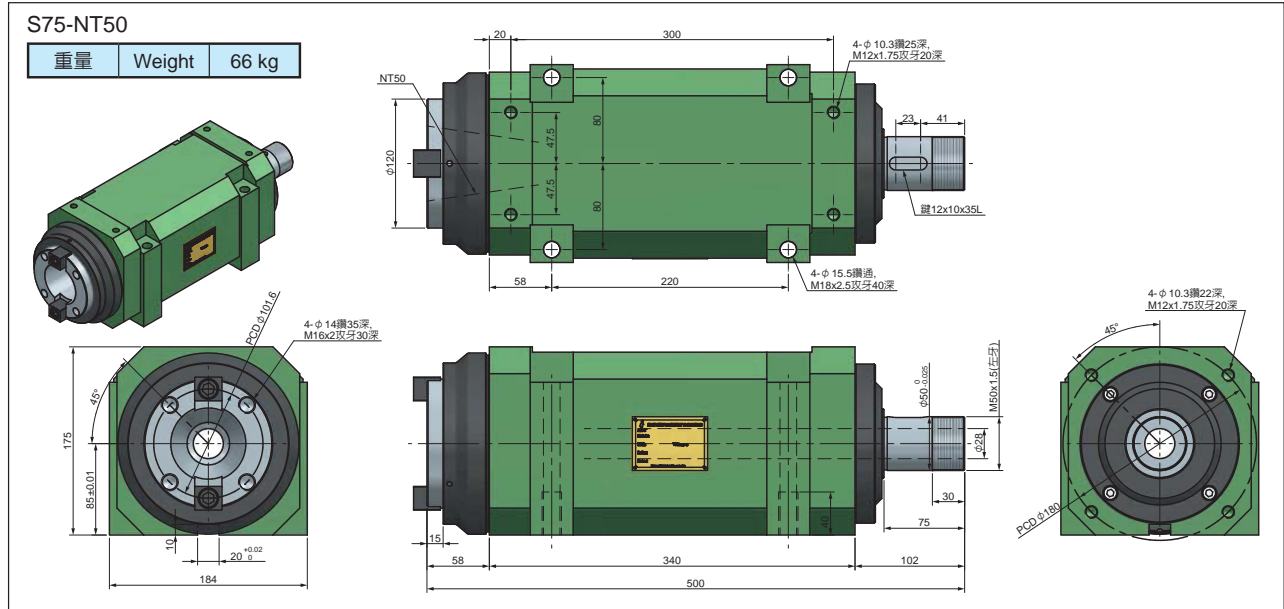

5037# S75 搪銑主軸頭 Boring & Milling Head Unit

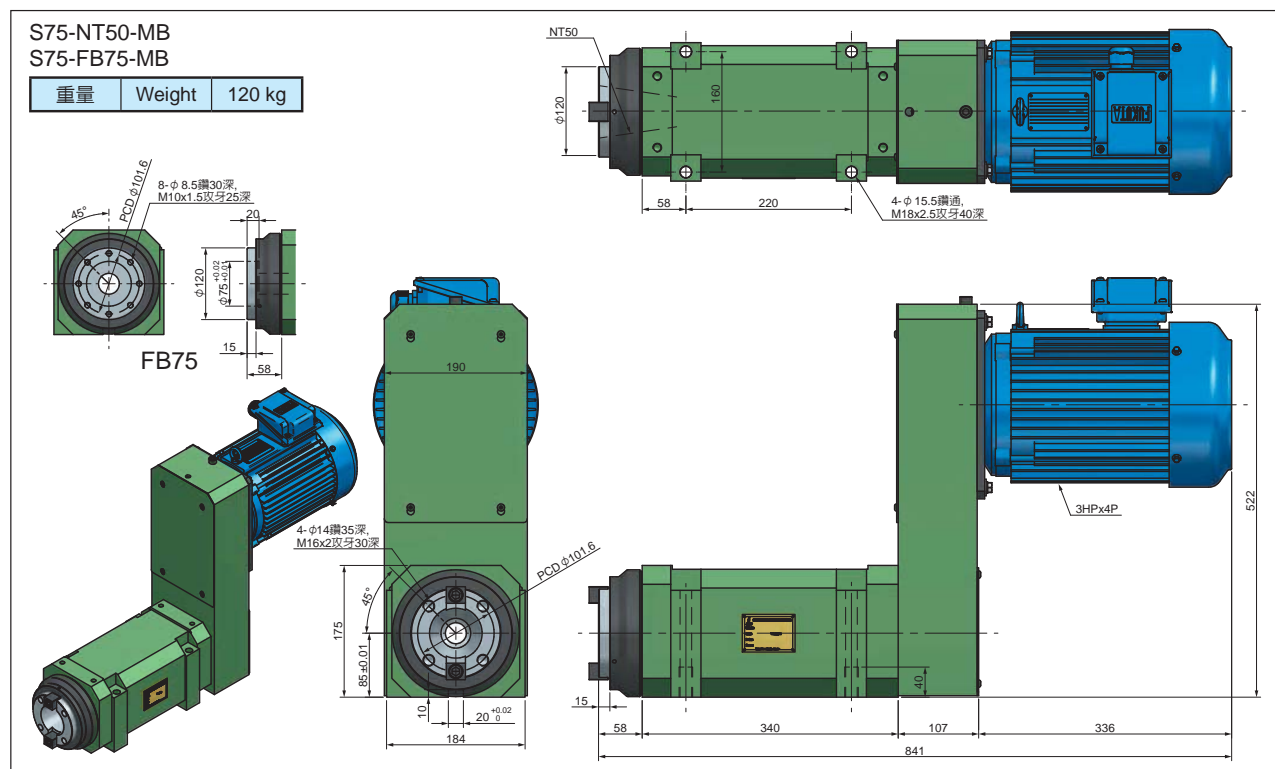
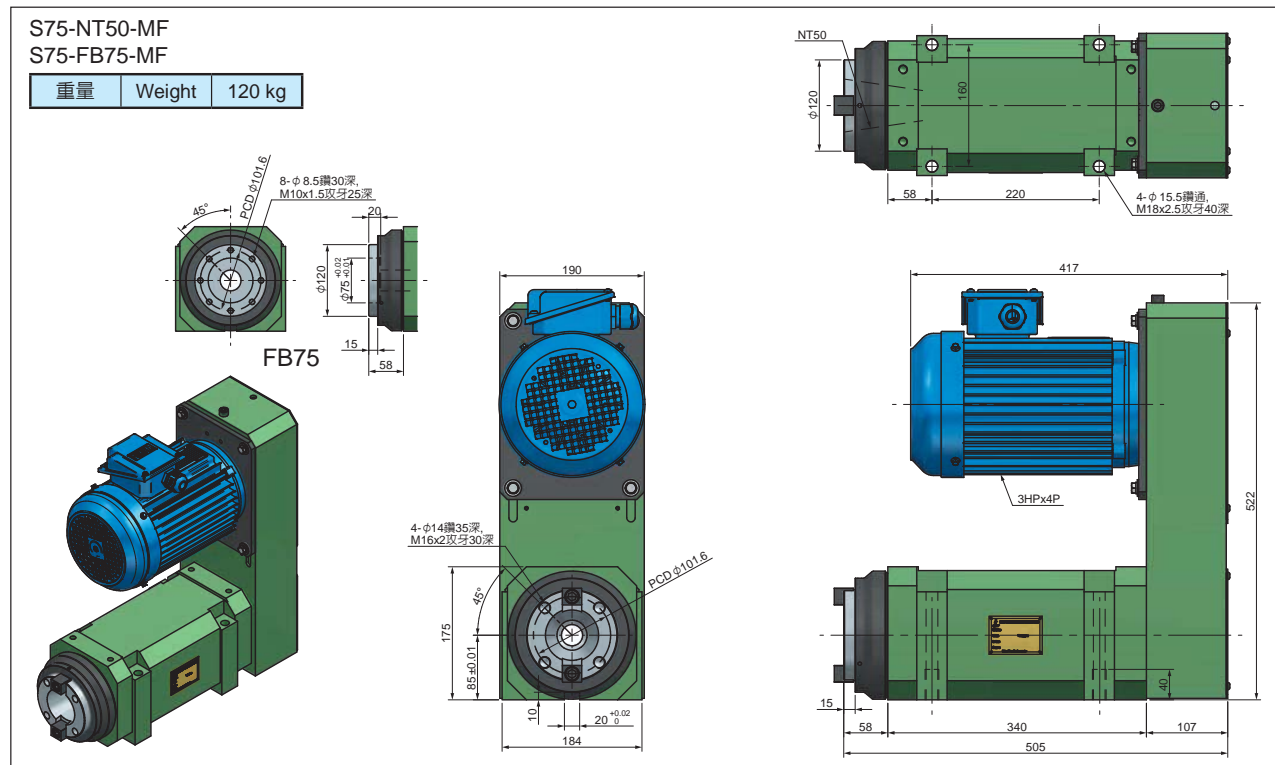



5038# S80 搪銑主軸頭 Boring & Milling Head Unit

規格	Model	S80	S80H
主軸	Spindle	NT50 or A2-5 or FB75	
最高轉速	Max. RPM	1200	3000
軸承	Bearing	32216x2 6216Zx2	7216x4
真圓度	Roundness	Within 0.003mm 內	
最大動力	Max. Power	Within 7.5 HP 內	
溫升	Rising Temperature	Within 20°C 內	

★出廠附精度檢驗表

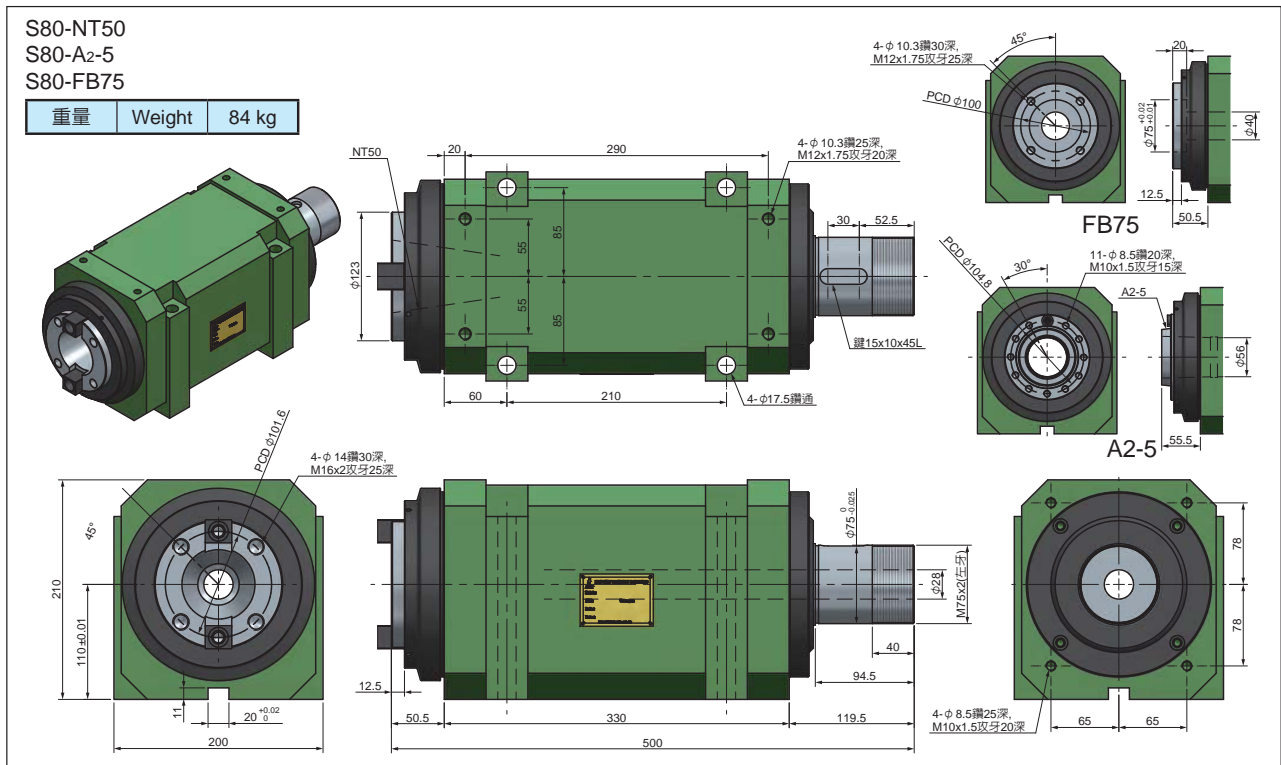

5038# S80 搪銑主軸頭 Boring & Milling Head Unit

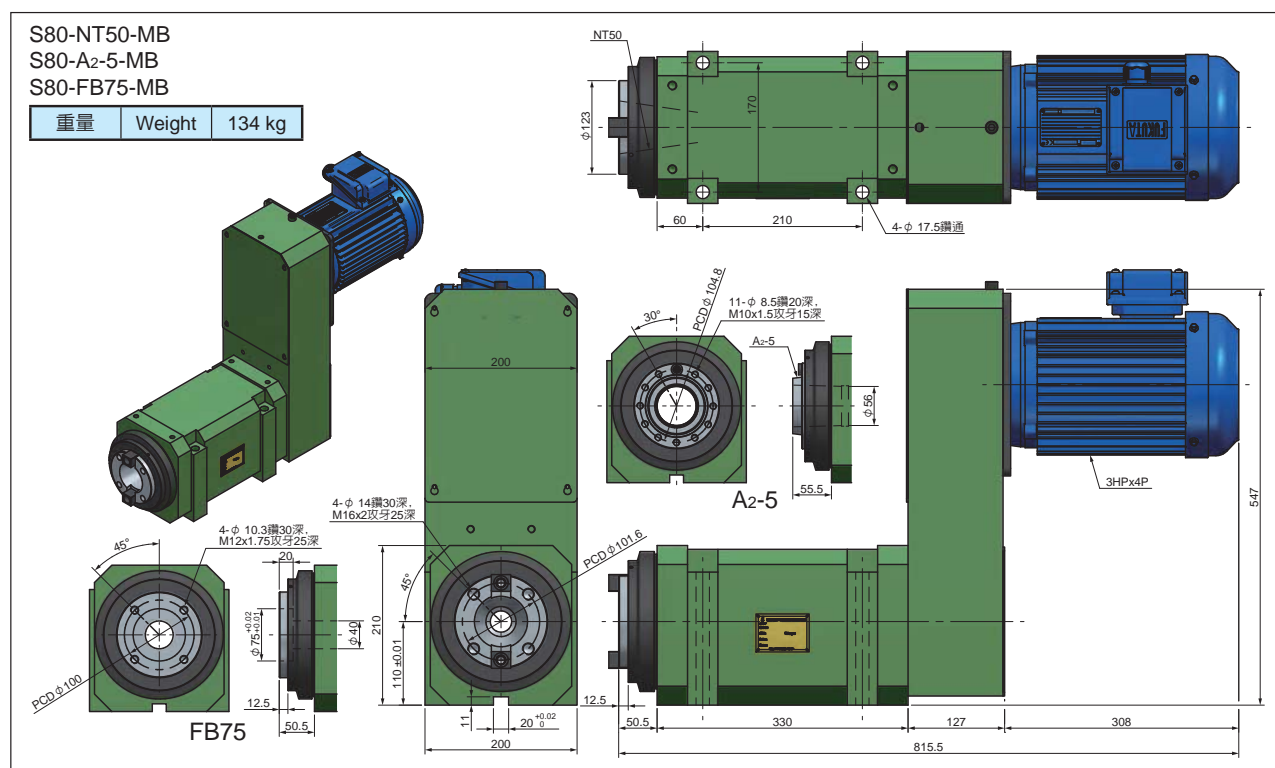
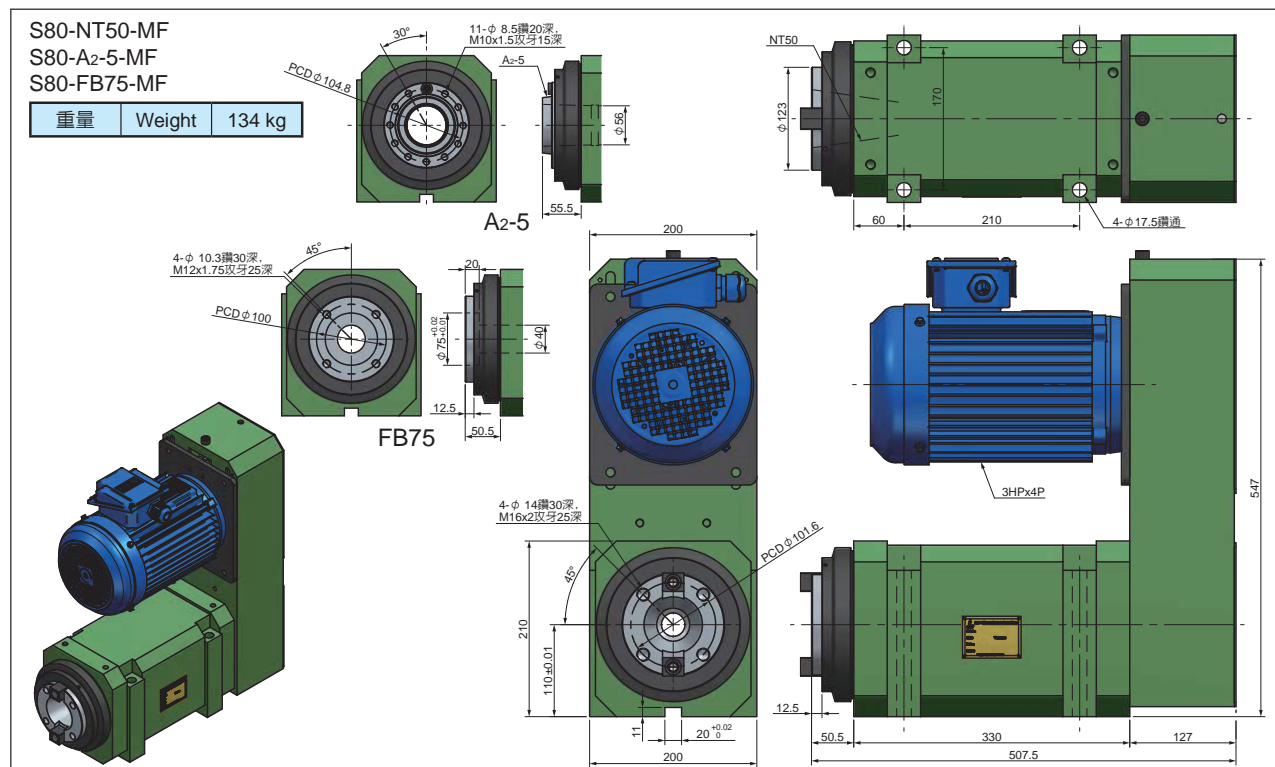



5039# S100,S120 搪銑主軸頭 Boring & Milling Head Unit

規格	Model	S100	S100H	S120	S120H
主軸	Spindle	NT50 or A2-6 or FB75		NT50 or A2-6	
最高轉速	Max. RPM	800	2500	600	2000
軸承	Bearing	6220Zx2 32220x2	7220x4	6224Zx2 32224x2	7224x4
真圓度	Roundness	Within 0.003mm 內			
最大動力	Max. Power	Within 15 HP 內		Within 20 HP 內	
溫升	Rising Temperature	Within 20°C 內			

★出廠附精度檢驗表

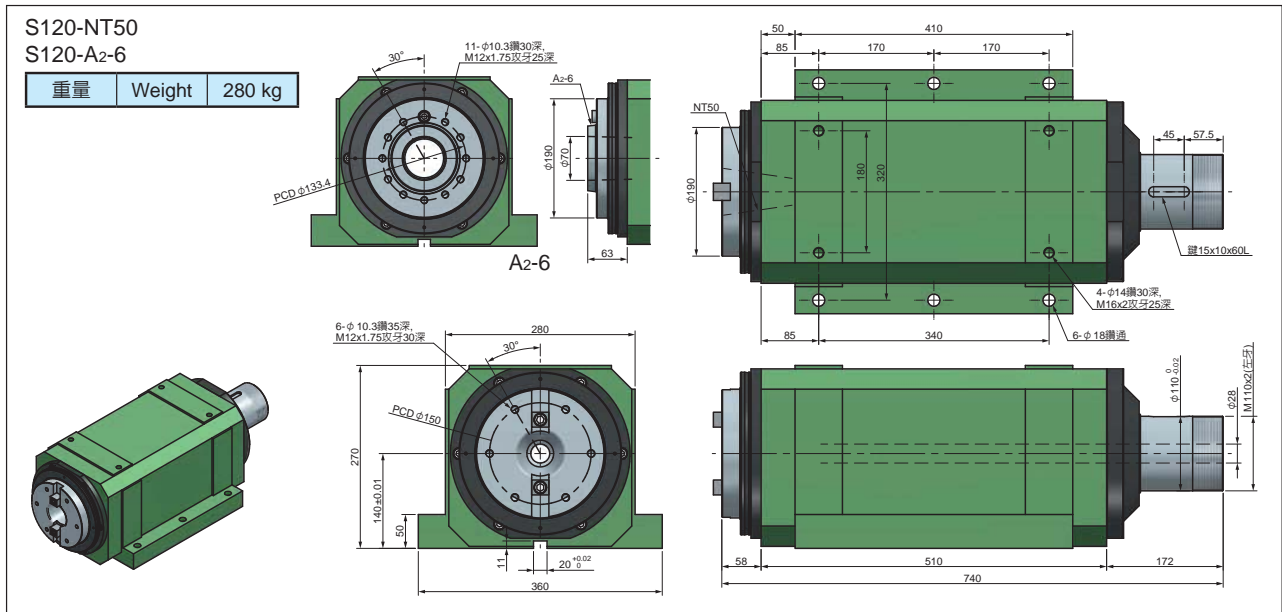
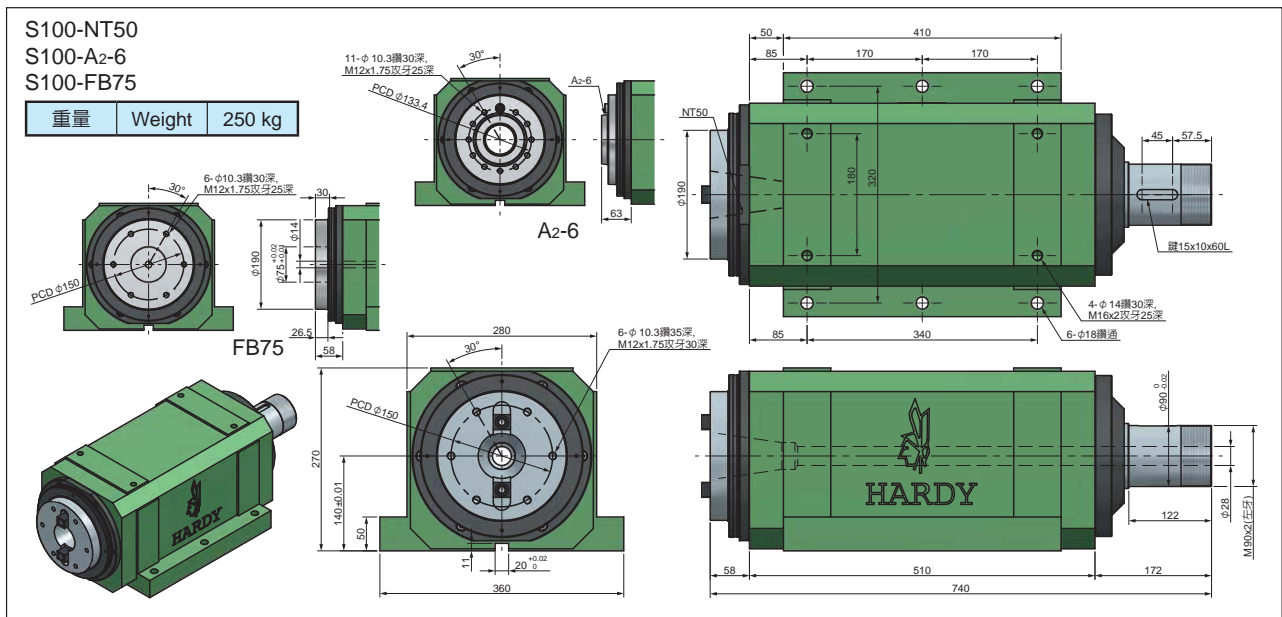



5039# S100,S120 搪銑主軸頭 Boring & Milling Head Unit

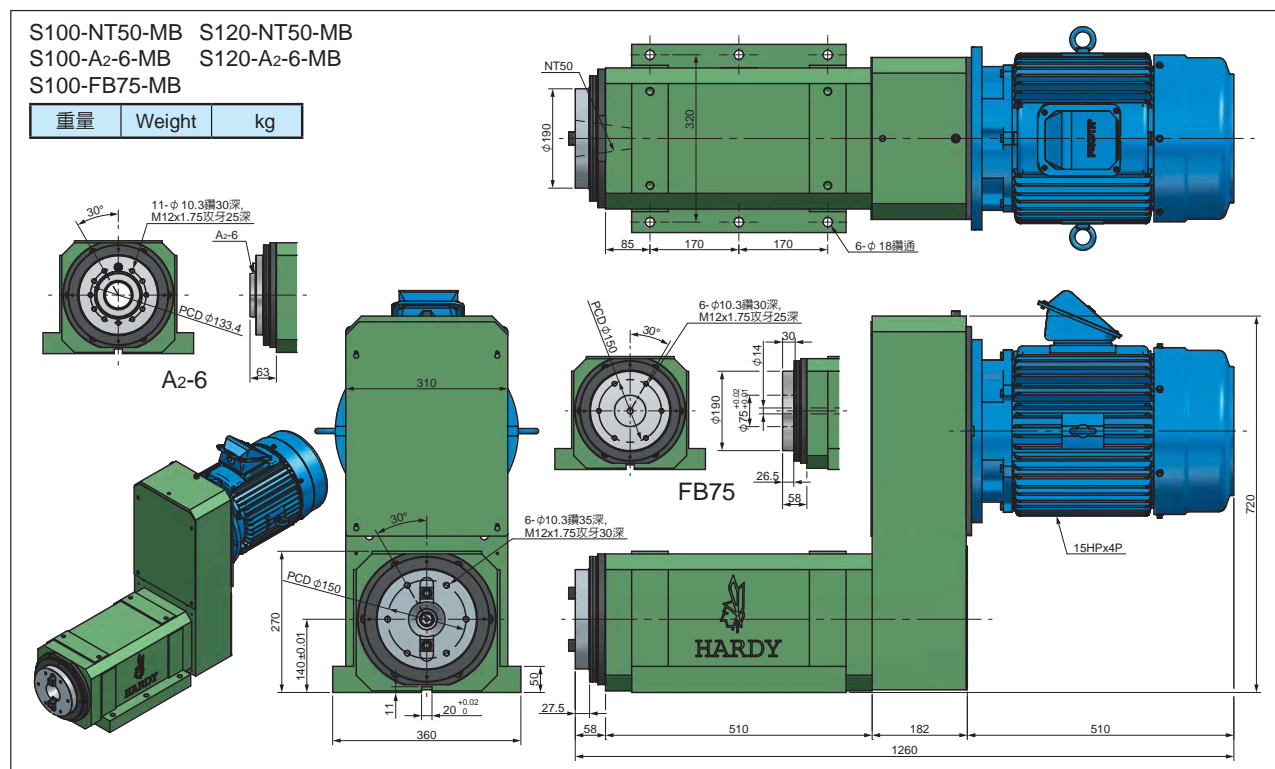
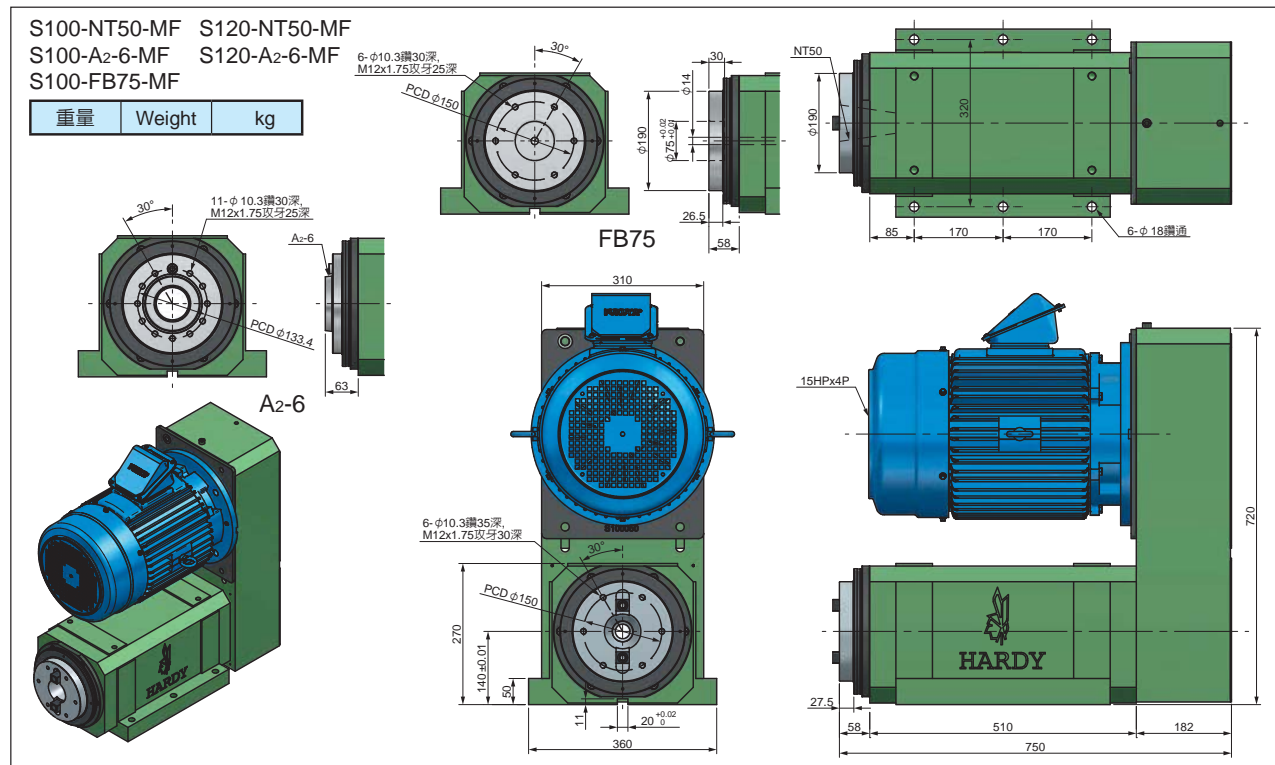



5040# SR35 搪銑主軸頭 Boring & Milling Head Unit

SR35-NT30-MF

重量	Weight	43 kg
----	--------	-------

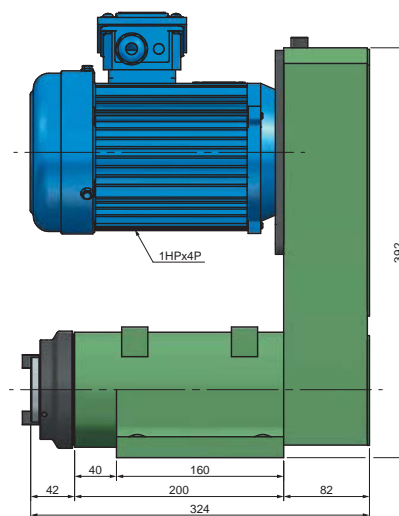
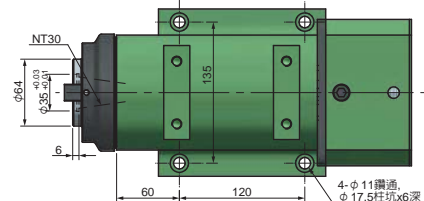
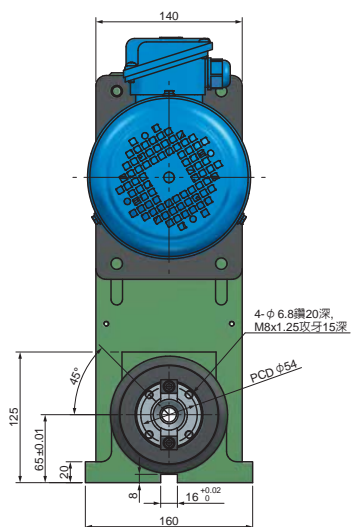
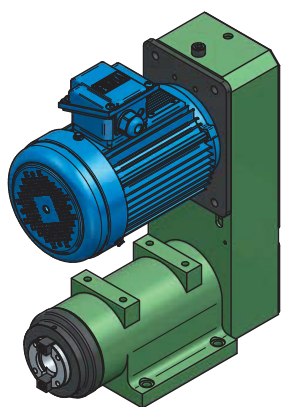

SR35-NT30-MB

重量	Weight	43 kg
----	--------	-------

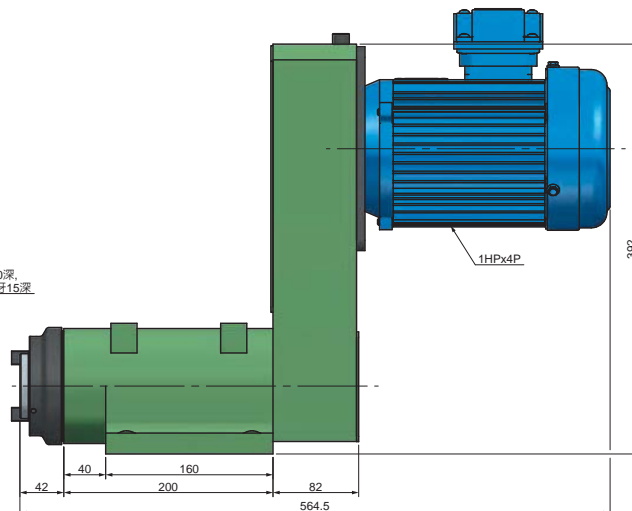
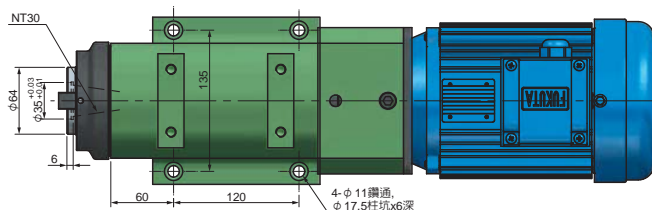
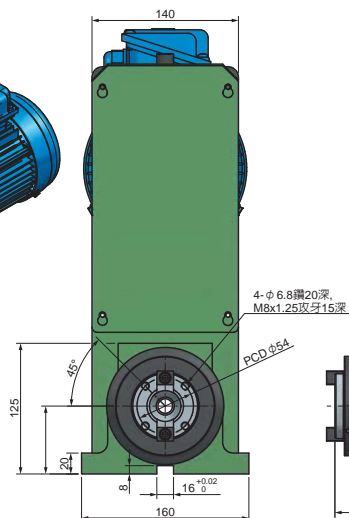
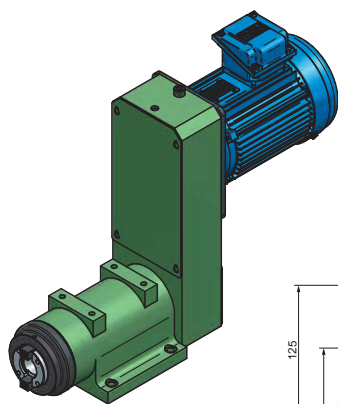

5041# SR45 搪銑主軸頭 Boring & Milling Head Unit

SR45-NT40-MF

重量	Weight	72 kg
----	--------	-------

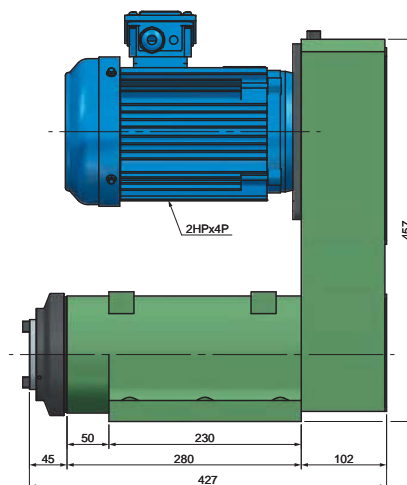
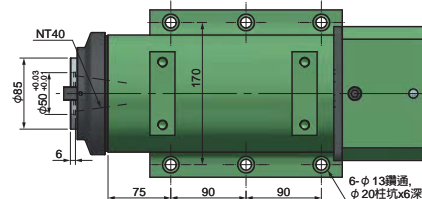
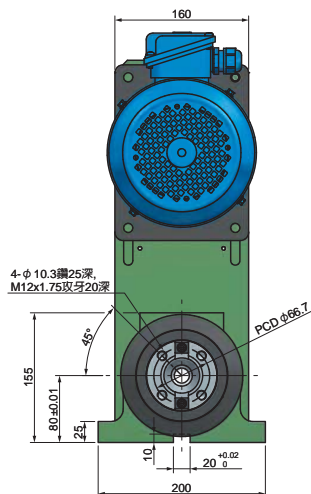
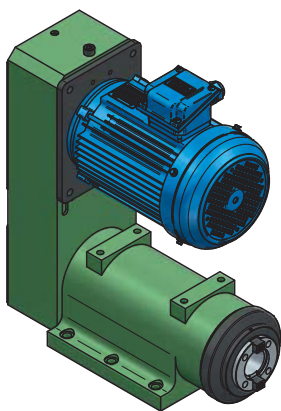

SR45-NT40-MB

重量	Weight	72 kg
----	--------	-------

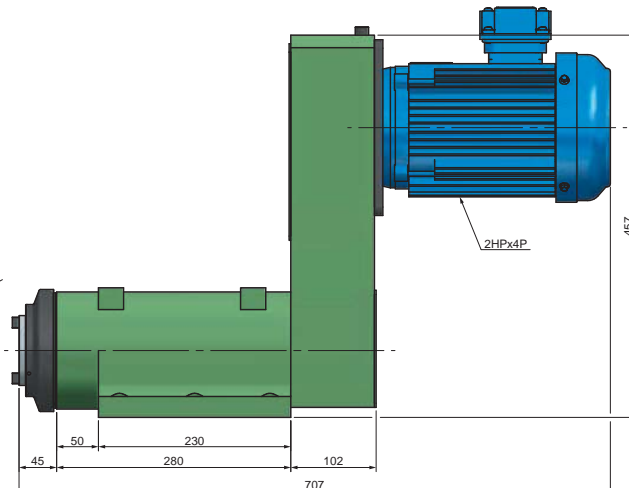
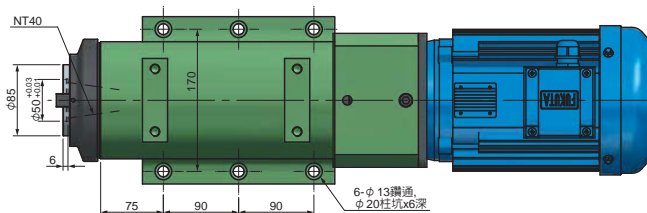
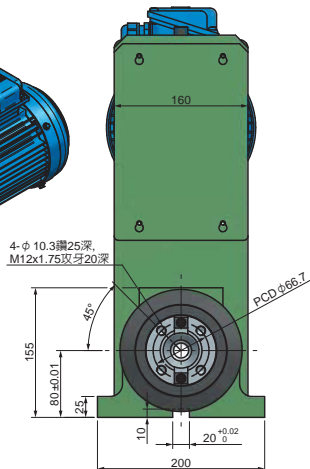
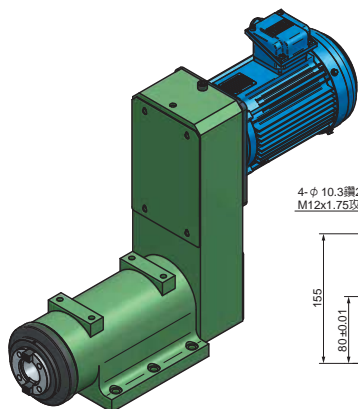



5042# SR60 搪銑主軸頭 Boring & Milling Head Unit

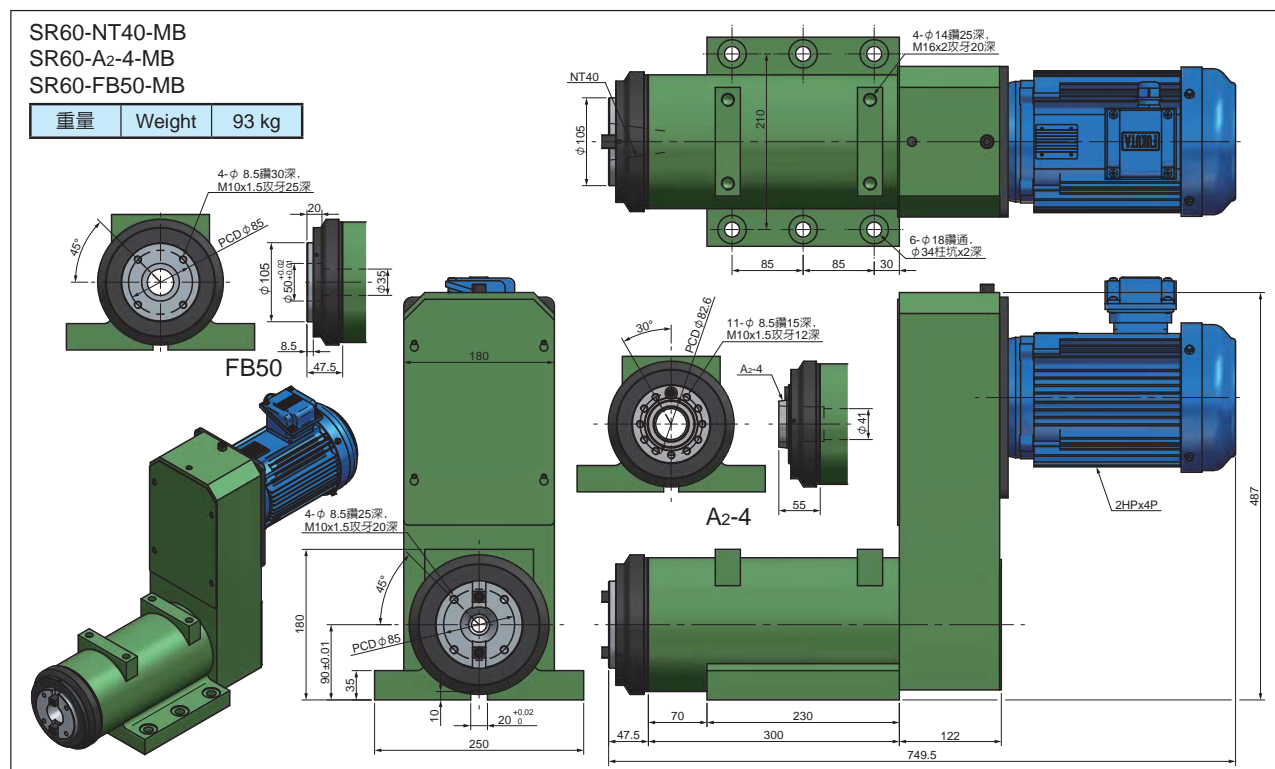
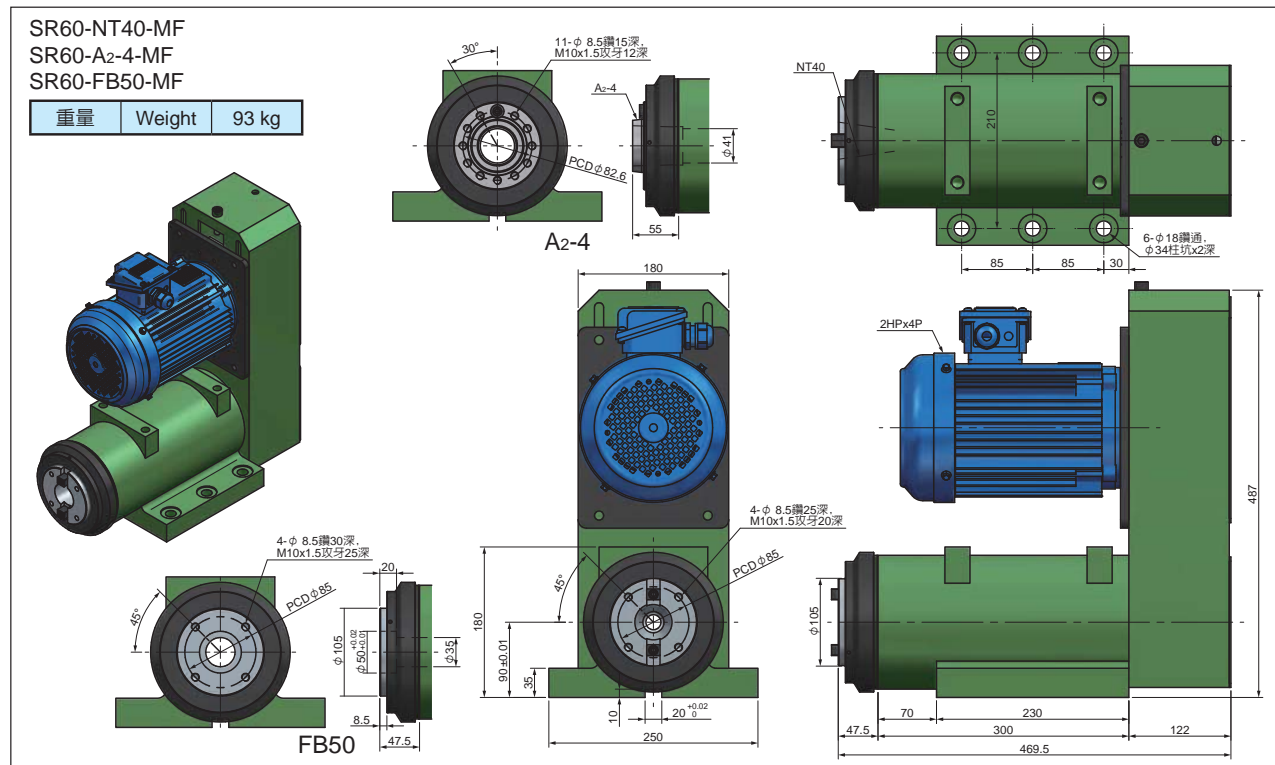



5043# SR80 搪銑主軸頭 Boring & Milling Head Unit

規格	Model	SR80	SR80H
主軸	Spindle	NT50 or A2-5 or FB75	
最高轉速	Max. RPM	1200	3000
軸承	Bearing	32216x2 6216Zx2	7216x4
真圓度	Roundness	Within 0.003mm 內	
最大動力	Max. Power	Within 7.5 HP 內	
溫升	Rising Temperature	Within 20°C 內	

★出廠附精度檢驗表

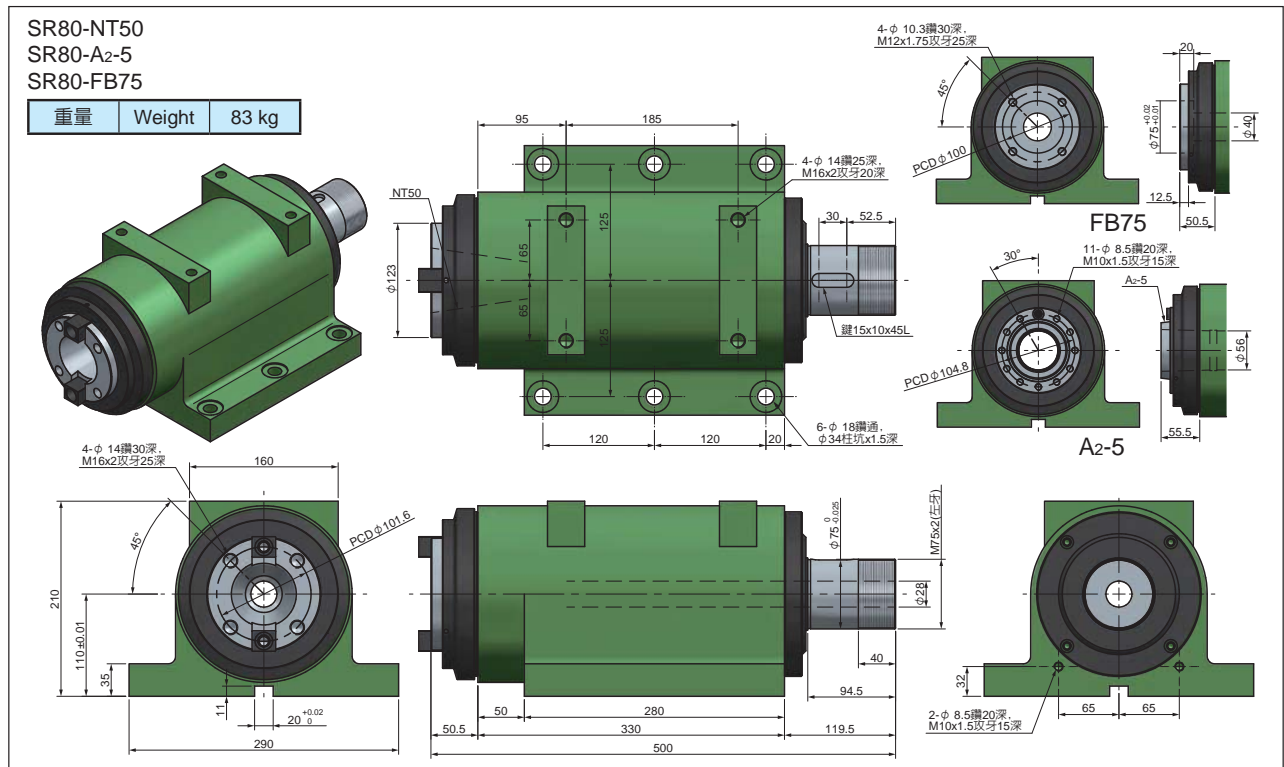

5043# SR80 搪銑主軸頭 Boring & Milling Head Unit

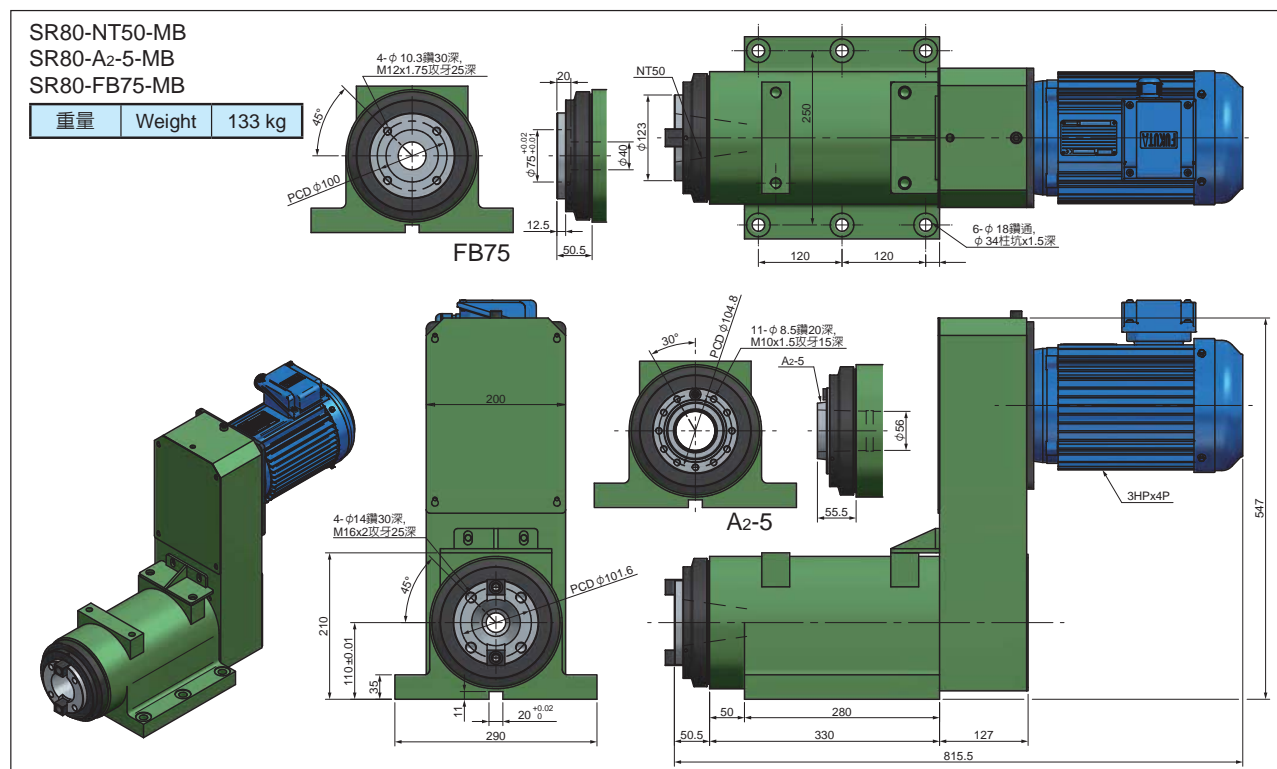
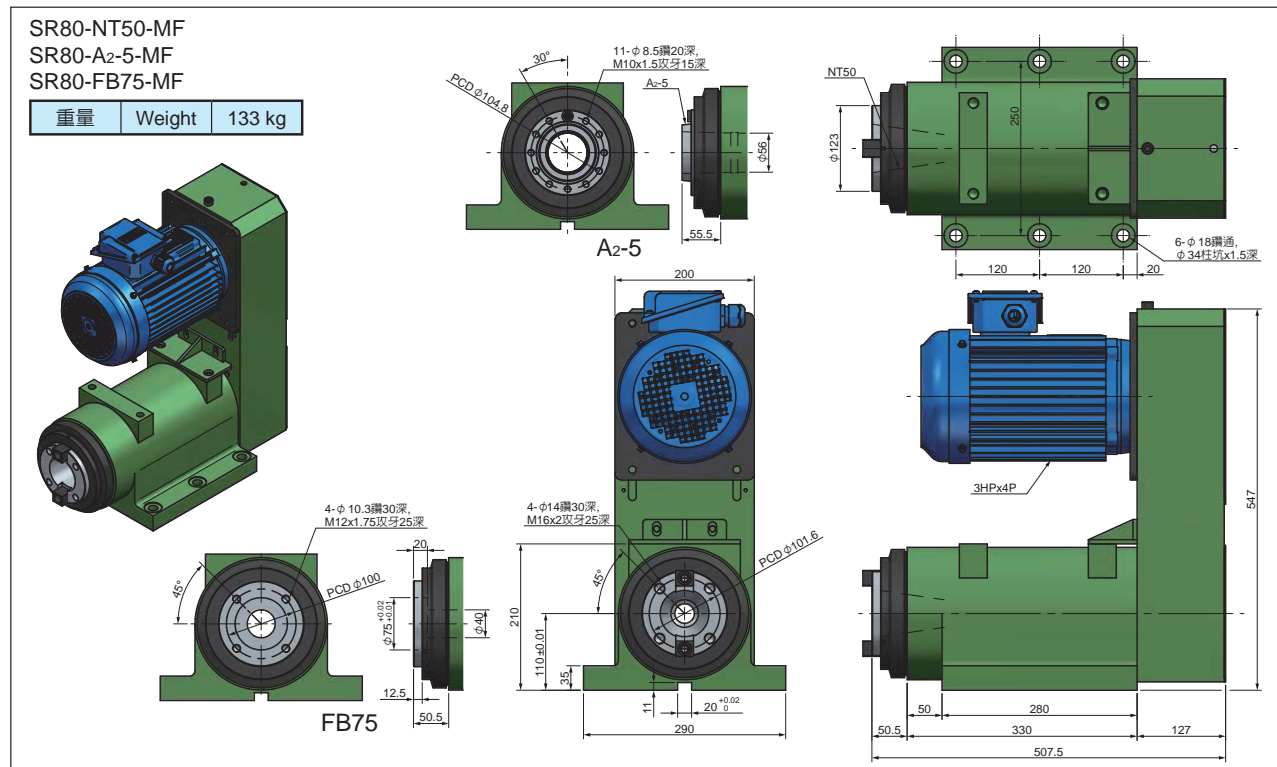



HARDY

5044# SRR35 搪銑主軸頭 Boring & Milling Head Unit

規格	Model	SRR35	SRR35H
主軸	Spindle	MT3 or ER32	
最高轉速	Max. RPM	3000	10000
軸承	Bearing	32007 / 6007Z 32006 / 6006Z	7007x2 7006x2
真圓度	Roundness	Within 0.003mm 內	
最大動力	Max. Power	Within 1 HP 內	
溫升	Rising Temperature	Within 20°C 內	

★出廠附精度檢驗表

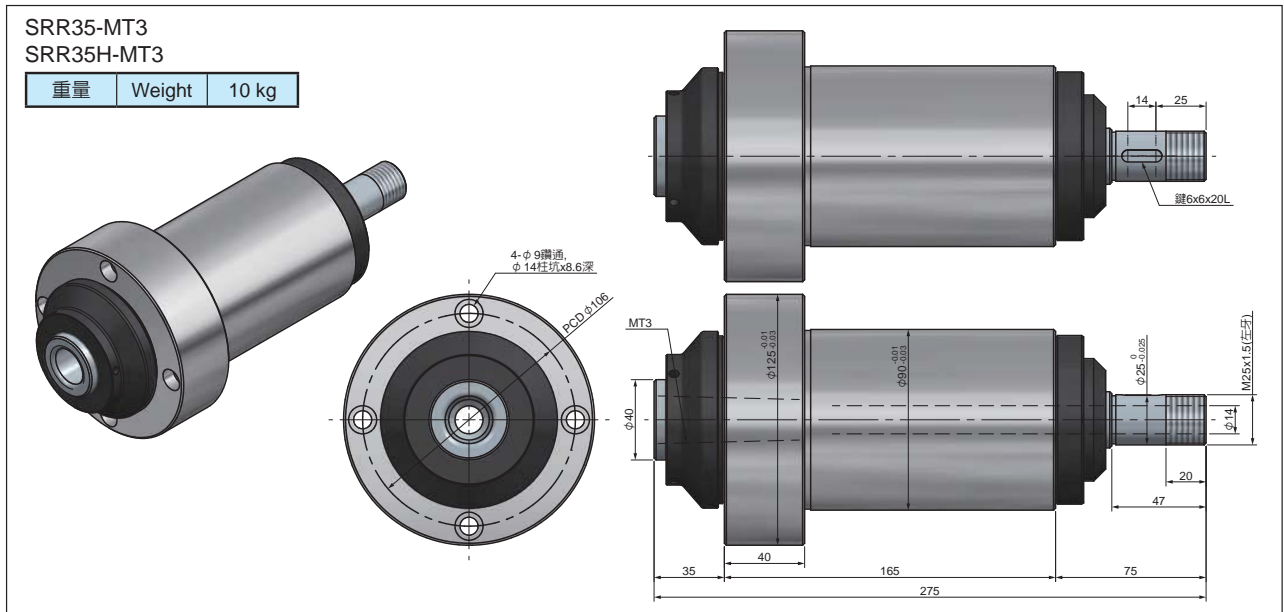
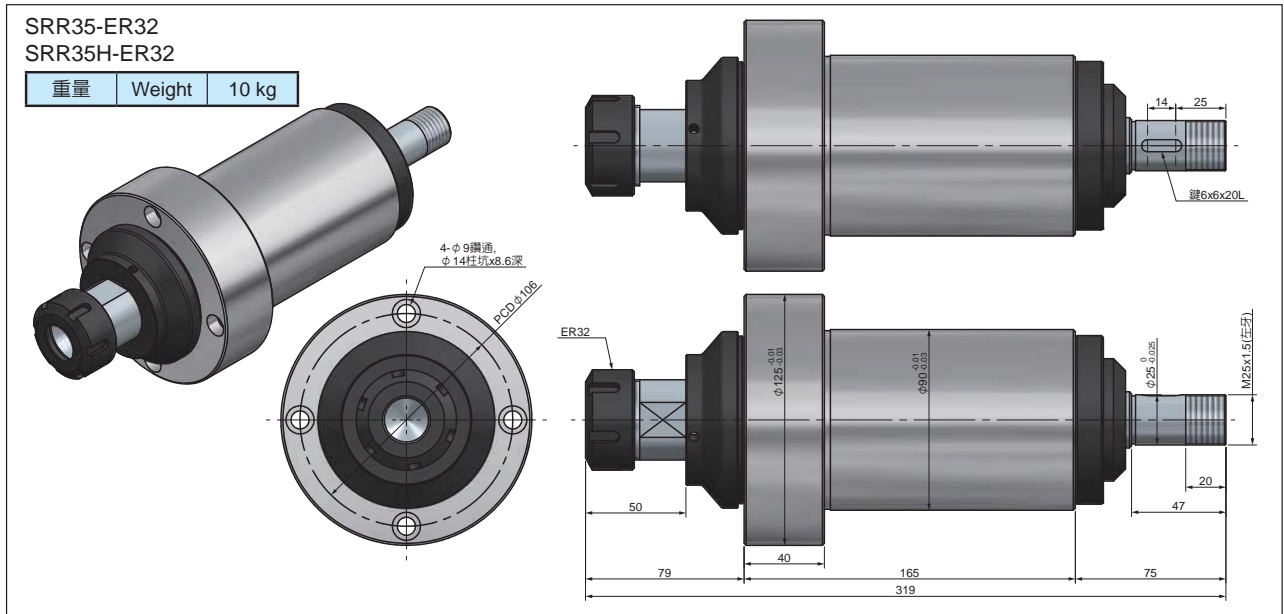

5045# SRR45 搪銑主軸頭 Boring & Milling Head Unit

規格	Model	SRR45	SRR45H
主軸	Spindle	NT30 or ER40	
最高轉速	Max. RPM	2500	8000
軸承	Bearing	32009 / 6009Z 32008 / 6008Z	7009x2 7008x2
真圓度	Roundness	Within 0.003mm 內	
最大動力	Max. Power	Within 2 HP 內	
溫升	Rising Temperature	Within 20°C 內	

★出廠附精度檢驗表

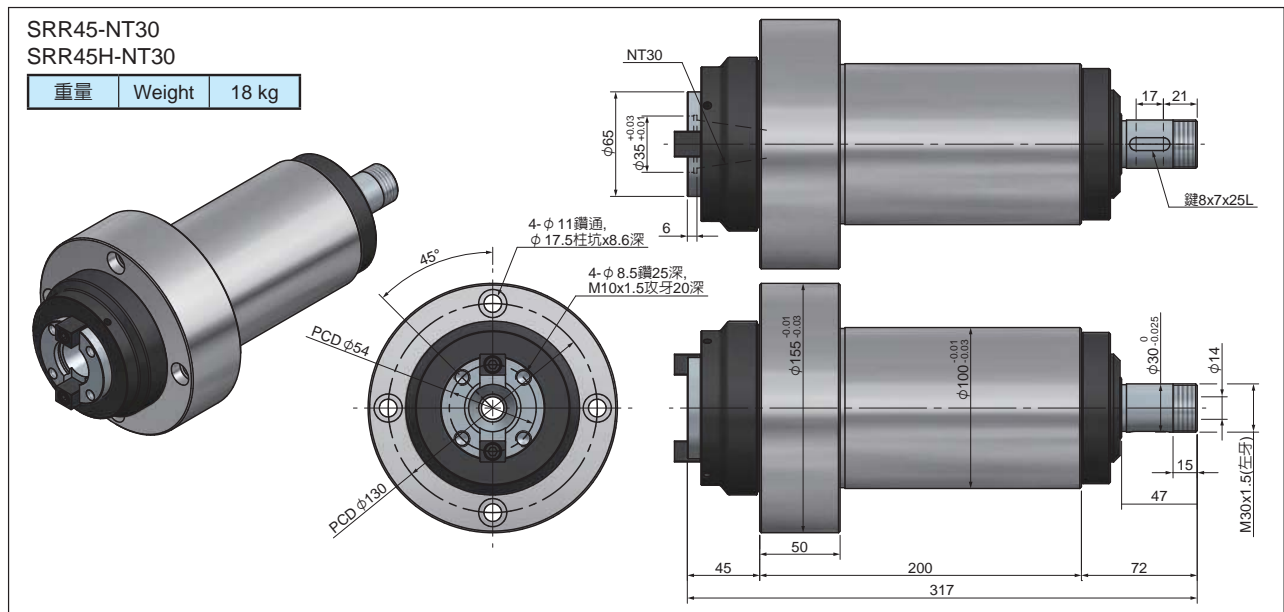
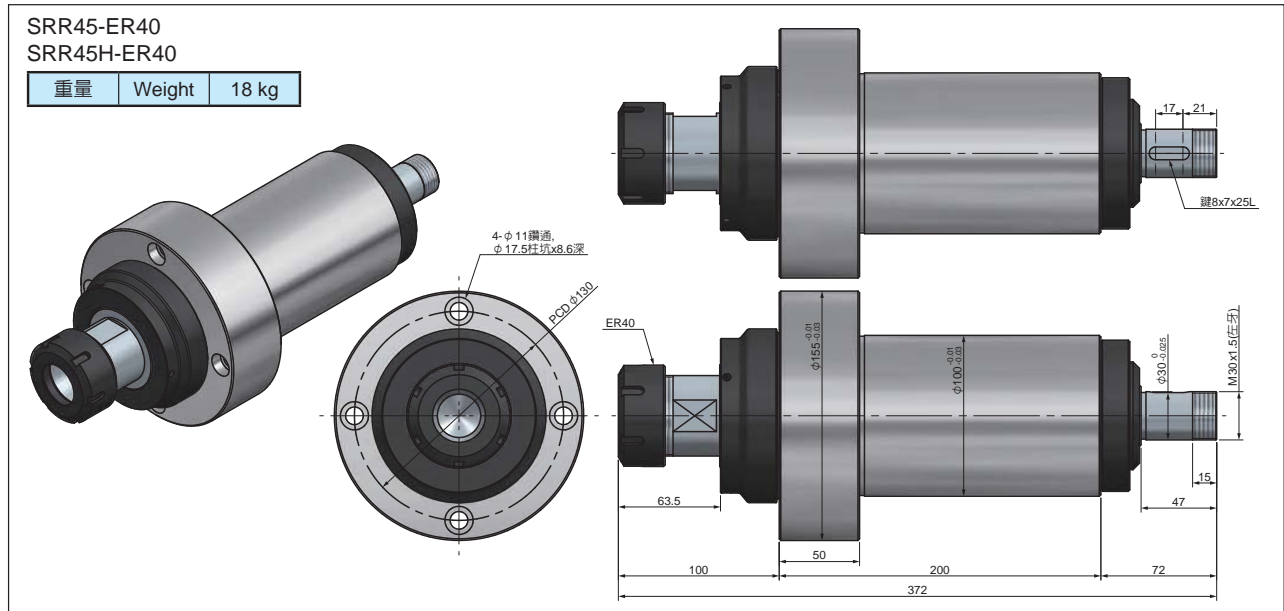



HARDY

5046# SRR55 搪銑主軸頭 Boring & Milling Head Unit

規格	Model	SRR55	SRR55H
主軸	Spindle	NT40 or MT4	
最高轉速	Max. RPM	2000	6000
軸承	Bearing	32011 / 6011Z 32010 / 6010Z	7011x2 7010x2
真圓度	Roundness	Within 0.003mm 內	
最大動力	Max. Power	Within 3 HP 內	
溫升	Rising Temperature	Within 20°C 內	

★出廠附精度檢驗表

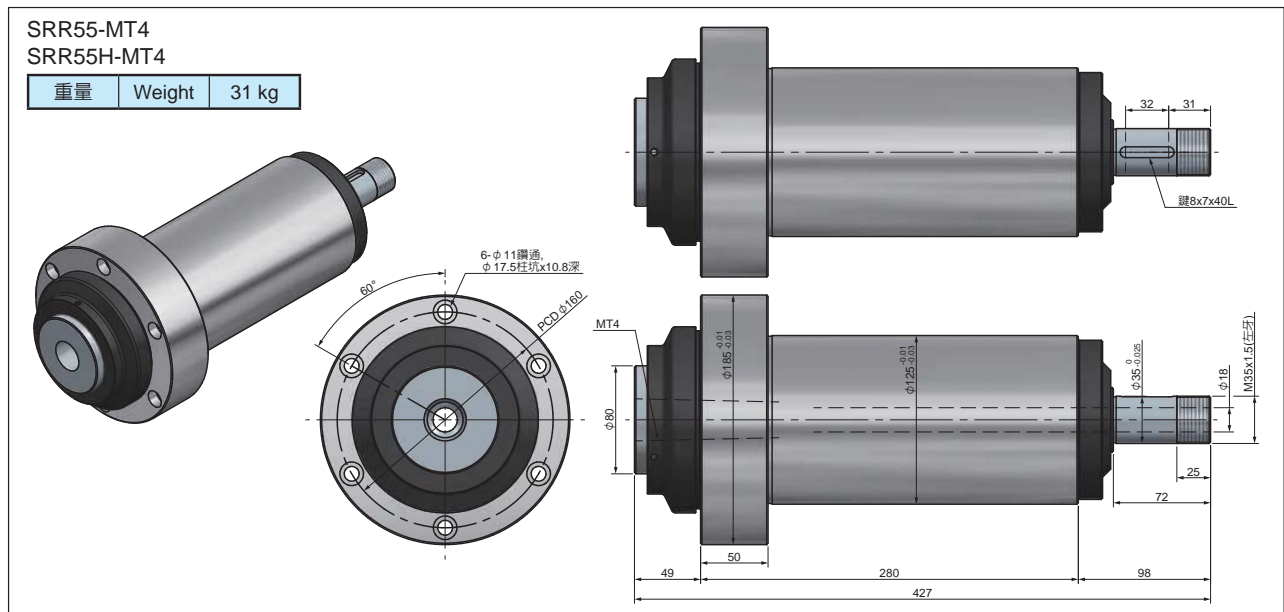
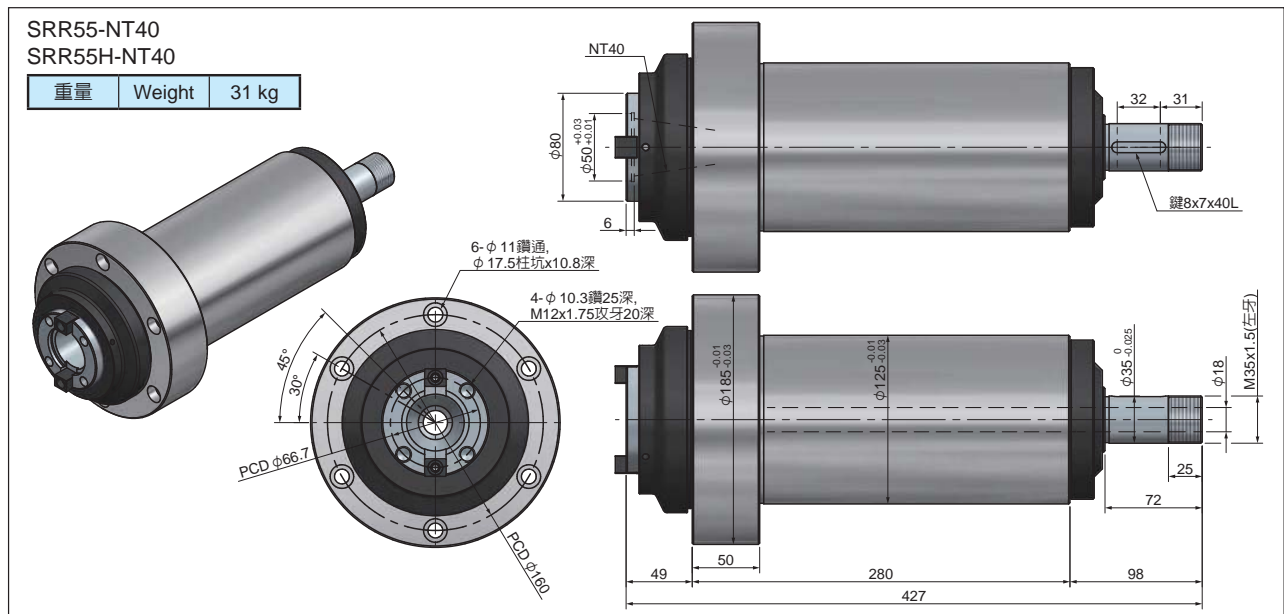

5047# SRR60 搪銑主軸頭 Boring & Milling Head Unit

規格	Model	SRR60	SRR60H
主軸	Spindle	NT40 or A2-4 or FB50	
最高轉速	Max. RPM	1800	5000
軸承	Bearing	32211 / 6211Z 32212 / 6212Z	7211x2 7212x2
真圓度	Roundness	Within 0.003mm 內	
最大動力	Max. Power	Within 5 HP 內	
溫升	Rising Temperature	Within 20°C 內	

★出廠附精度檢驗表

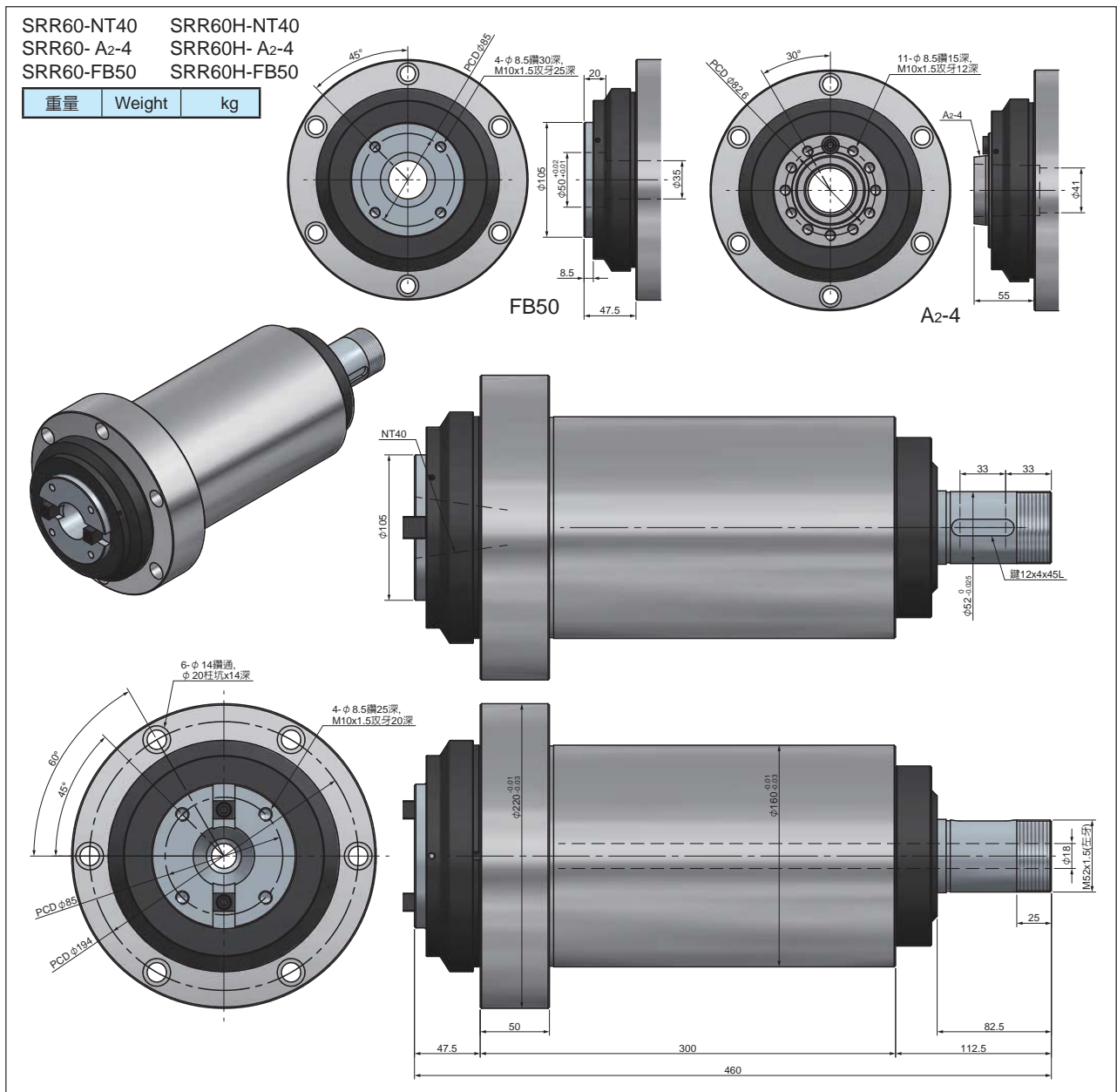



HARDY

5048# SRR75 搪銑主軸頭 Boring & Milling Head Unit

規格	Model	SRR75	SRR75H
主軸	Spindle	NT50 or FB75	
最高轉速	Max. RPM	1600	4000
軸承	Bearing	32015 / 6015Z 32014 / 6014Z	7015x2 7014x2
真圓度	Roundness	Within 0.003mm 內	
最大動力	Max. Power	Within 5 HP 內	
溫升	Rising Temperature	Within 20°C 內	

★出廠附精度檢驗表

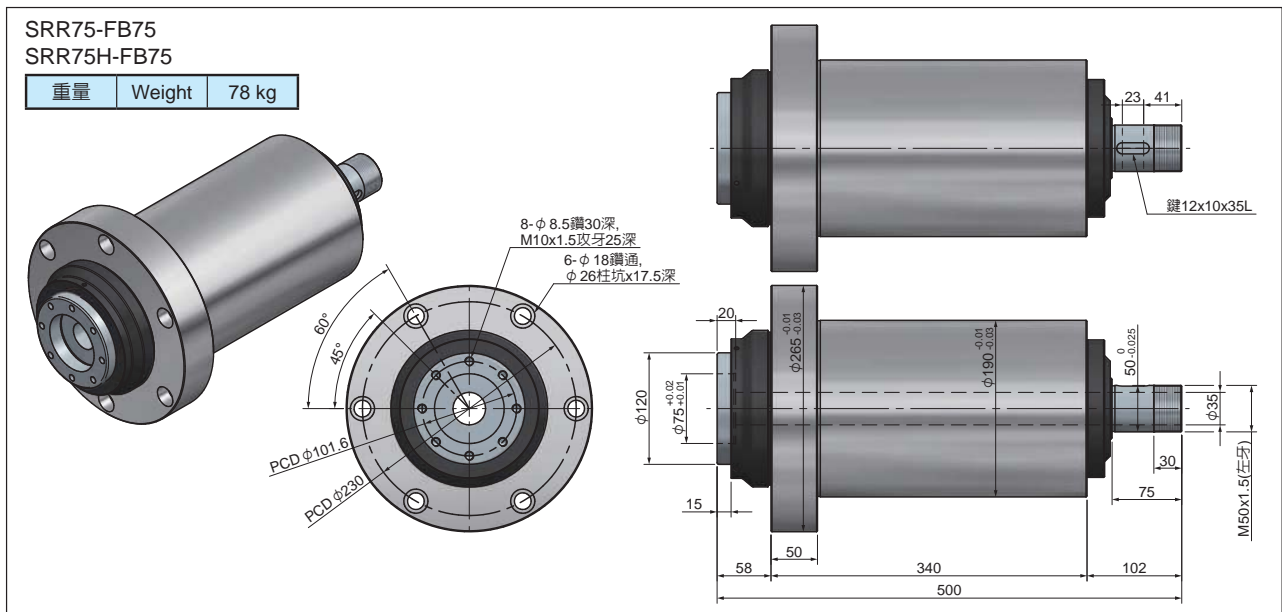
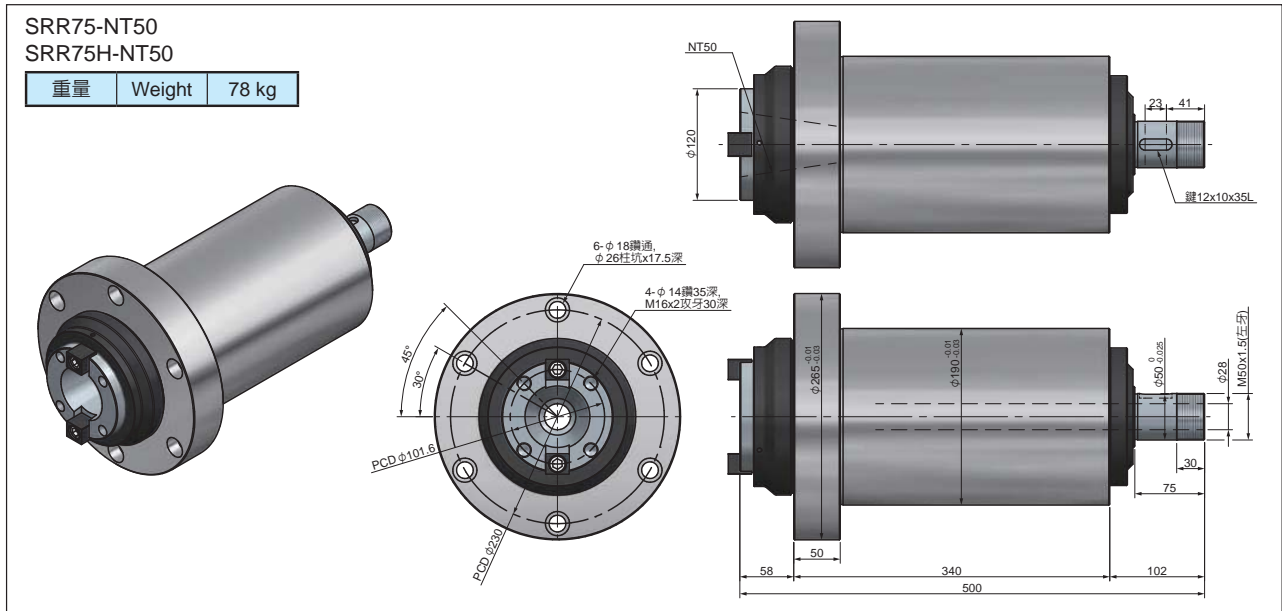

5049# SRR80 搪銑主軸頭 Boring & Milling Head Unit

規格	Model	SRR80	SRR80H
主軸	Spindle	NT50 or A2-5 or FB75	
最高轉速	Max. RPM	1200	3000
軸承	Bearing	32216x2 6216Zx2	7216x4
真圓度	Roundness	Within 0.003mm 內	
最大動力	Max. Power	Within 7.5 HP 內	
溫升	Rising Temperature	Within 20°C 內	

★出廠附精度檢驗表

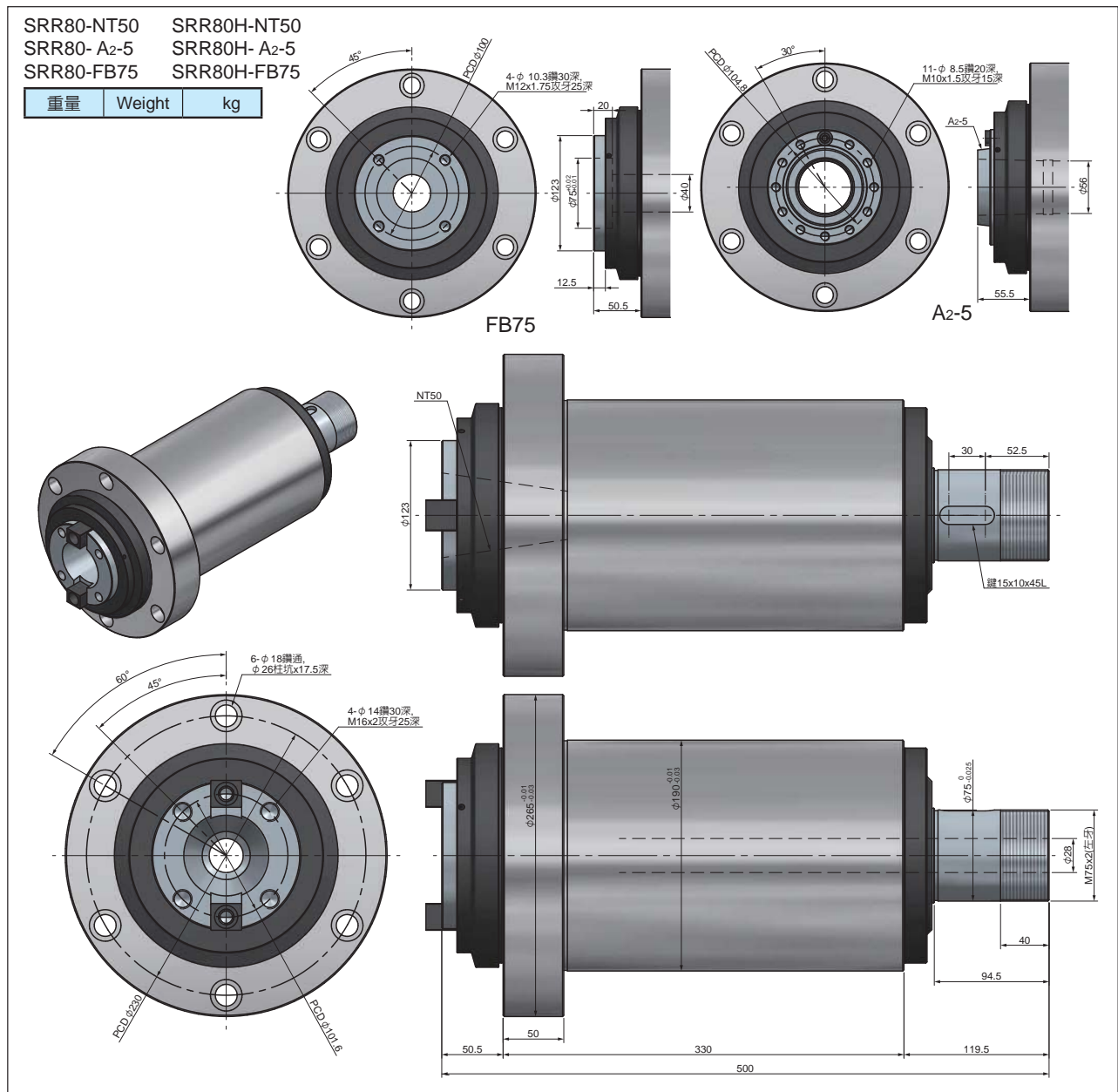



5050# A級精度檢測主軸頭
Precision Test Spindle

規格	Model	SR35-NT30-T	SR45-NT40-T	SR80-NT50-T
主軸	Spindle	NT30 or BT30	NT40 or BT40	NT50 or BT50
真圓度	Roundness	Within 0.002mm 內		

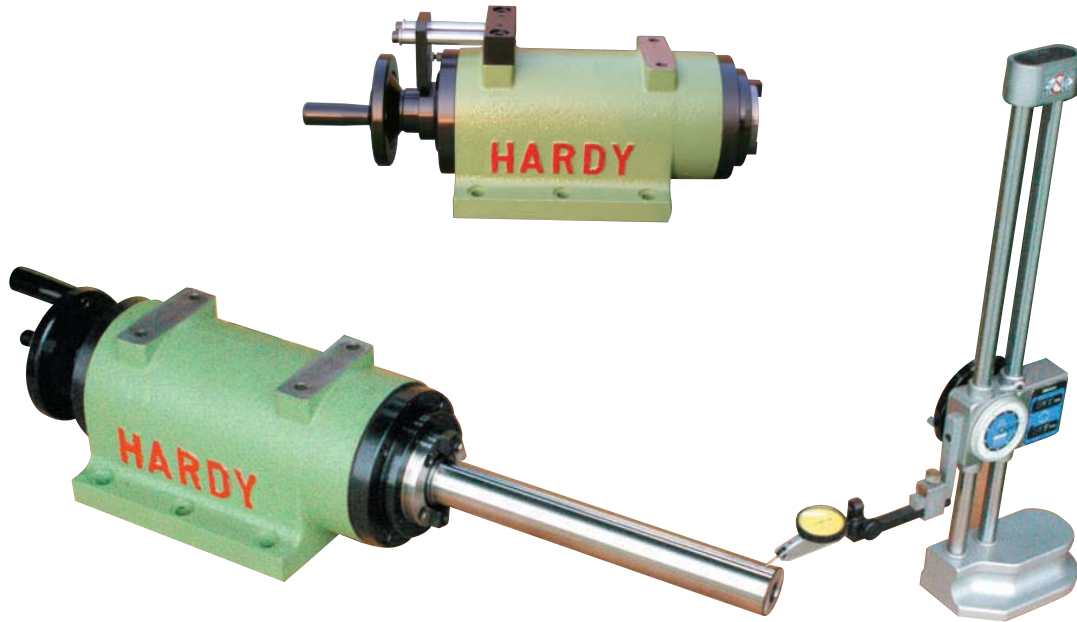

SR35-NT30-T
SR45-NT40-T
SR80-NT50-T

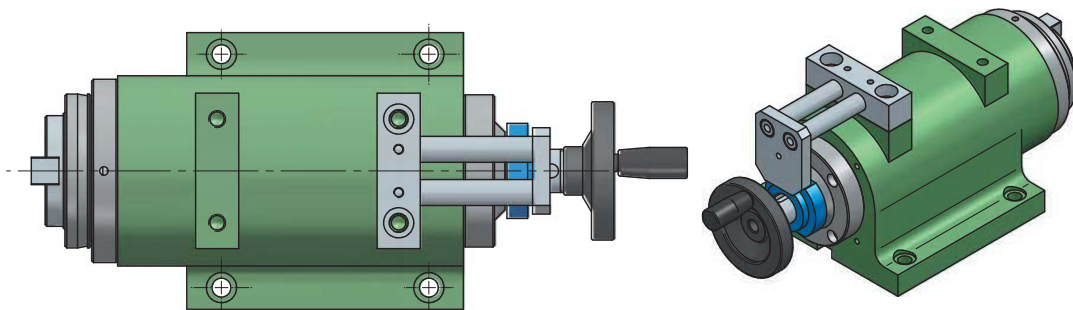

可接受特殊規格動力頭訂製
We accept Special Spindle Unit Order

